



## PARTICIPANT GUIDE



# BEB Familiarization Course: Battery Electric Bus Familiarization

## DISCLAIMER

Disclaimer: This course is intended to educate employees of public transportation systems that have agreed to voluntarily partake in this training course. It is intended only as informal guidance on the matters addressed, and should not be relied upon as the only method or manner for performing the tasks or work outlined in the materials. Anyone using this document or information provided in the associated training program should rely on his or her own independent judgment, or as appropriate, seek the advice of a competent professional in determining the exercise of care in any given circumstances. These materials are based on compendiums of knowledge from transit employees, manufacturers, and outside consultants, each of whom may approach a repair, update, or maintenance in their own unique way. Always follow the safety and maintenance procedures from your own agency, union, relevant OEM(s) and/or regulatory organizations. In addition, the course materials include examples from member agencies, nomenclature, procedures, and configurations that can vary from one transit location to another. The document you are now referencing may have been modified by the Transit Workforce Center.

The Transit Workforce Center, as well as the International Transportation Learning Center and its participating agencies and labor unions, make no guarantee or warranty as to the accuracy or completeness of any information provided herein. The Transit Workforce Center, as well as the International Transportation Learning Center and its participating agencies and labor unions, disclaim liability for any injury or other damages of any nature whatsoever, directly or indirectly, resulting from the use of or reliance on this document or the associated training program.

Note: All images contained within this document were contributed by the Transit Workforce Center otherwise noted.

## REVISION INDEX

Additions, deletions, or revisions are listed in the table below.

| Date | Module and Section | Description of Change | Revision Author |
|------|--------------------|-----------------------|-----------------|
|      |                    |                       |                 |
|      |                    |                       |                 |
|      |                    |                       |                 |
|      |                    |                       |                 |
|      |                    |                       |                 |
|      |                    |                       |                 |

## HOW TO USE THE PARTICIPANT GUIDE

### Purpose of the Course

This course offers participants an overview to what a battery electric bus [BEB] is, what features allow it to function similarly and differently from standard internal combustion engines [ICE] and hybrid buses, safety guidelines, protocols, PPE and preventive maintenance practices, and an overview into the types of charging technologies and maintenance. Learning applications are built into this course to reinforce a comprehensive, engaging, and hands-on approach to familiarizing participants with BEB safety, features, and functions.

Overall goals for the overall course include:

- 1) Describe the features and operational characteristics of BEBs
- 2) Identify and explain key functions of BEB high-voltage systems and their major components
- 3) Identify safety hazards related to high-voltage BEB systems
- 4) Explain high-voltage system safety features
- 5) Identify training requirements for personnel performing maintenance on high-voltage systems
- 6) Identify and demonstrate proper use and inspection of PPE require while performing maintenance on high-voltage systems
- 7) Identify and explain the purpose of safety and testing equipment & special tools required or recommended for performing maintenance on high voltage systems
- 8) Demonstrate electrical de-energization procedures for original equipment manufacturer [OEM] BEBs
- 9) Discuss SAE charging standards, technologies, and equipment relevant to BEBs
- 10) Demonstrate proper use and maintenance of Electric Vehicle Supply Equipment [EVSE] charging

### Approach of the Course

Each course module begins with an outline, a learning outcome statement, a list of key terms, and a list of any acronyms that may appear in the text. The outline will discuss the main topics to be addressed in the module. The *Learning Outcome* lists the basic skills, knowledge, and abilities course participants should be able to demonstrate to show that they have learned the material presented in the module. A list of *key terms* identifies important terminology that will be introduced in this module. Several *Learning Applications* (Exercises) are built in throughout the course materials to supplement the participants in learning, reviewing, and understanding key information. This course also utilizes engaging exercises and video demonstrations to allow participants to visually understand exactly what materials, steps and procedures are taken during electric bus maintenance.

## Contents

|   |           |
|---|-----------|
| Disclaimer .....  | ii        |
| How to Use the Participant Guide .....  | iii       |
| Table of Figures .....  | v         |
| <b>MODULE 1.....</b>  | <b>1</b>  |
| <b><i>Battery Electric Bus Overview: Fundamentals.....</i></b>                            | <b>1</b>  |
| 1-1 Overview.....   | 3         |
| 1-2 BEBs vs. ICE vs. Hybrid Buses.....  | 4         |
| 1-3 Details of BEB Systems and Components .....   | 9         |
| 1-4 BEB High-Voltage Identification & Risks, System Cooling, and Data Communications..... | 21        |
| 1-5 Battery Management & Cooling.....   | 33        |
| 1-6 Preventive Maintenance .....  | 41        |
| 1-7 Summary.....  | 48        |
| <b>MODULE 2.....</b>  | <b>49</b> |
| <b><i>Electrical Safety &amp; Personal Protective Equipment.....</i></b>                  | <b>49</b> |
| 2-1 Overview.....   | 50        |
| 2-2 Fundamentals & Safety Considerations.....   | 51        |
| 2-3 Personal Protective Equipment [PPE] .....   | 76        |
| 2-4 Safety & Testing Equipment .....  | 80        |
| 2-5 De-Energizing [Lock-out/Tag-out] of BEB Electrical Systems.....                       | 84        |
| 2-6 Summary.....  | 88        |
| <b>MODULE 3.....</b>  | <b>89</b> |
| <b><i>Battery Charging Technologies .....</i></b>   | <b>89</b> |
| 3-1 Overview.....   | 90        |
| 3-2 Charging Overview.....  | 90        |
| 3-3 Electric Vehicle Charging Standards.....  | 94        |
| 3-4 Details of Charging Technologies .....  | 97        |
| 3-5 Brief Charging Precautions .....  | 105       |
| 3-6 Summary.....  | 107       |

## Table of Figures

|   |    |
|---|----|
| Figure 1 Technicians performing maintenance on a BEB .....  | 3  |
| Figure 2 Vendor diagrams of a Battery Electric Bus .....  | 4  |
| Figure 3 BEB air system .....   | 5  |
| Figure 4 BEB suspension .....   | 5  |
| Figure 5 BEB Powertrain .....   | 6  |
| Figure 6 Primary SAE standards for charging .....   | 7  |
| Figure 7 Overhead charging units .....  | 8  |
| Figure 8 Inductive charging diagram .....   | 8  |
| Figure 9 BEB Traction motor process .....   | 10 |
| Figure 10 Manual/External Charge Port .....   | 11 |
| Figure 11 ESS Makeup diagram .....  | 11 |
| Figure 12 Example location of HVJB .....  | 12 |
| Figure 13 BEB Inverters .....   | 12 |
| Figure 14 Diagram of alternating current in an inverter .....   | 12 |
| Figure 15 DC to DC converter .....  | 13 |
| Figure 16 Electrical Switching Device .....   | 13 |
| Figure 17 Electronic Controller .....   | 13 |
| Figure 18 HV Cables .....   | 13 |
| Figure 19 BEB HVAC breakdown diagram .....  | 14 |
| Figure 20 Water cooled rotary vane with an AC motor diagram and drive motor – courtesy AC Transit ..... | 14 |
| Figure 21 Midsection of a BEB Traction motor - courtesy of AC Transit .....                             | 14 |
| Figure 22 BEB diagram clear .....   | 16 |
| Figure 23 Power flow inverters diagrams .....   | 17 |
| Figure 24 Model of a traction rotor .....   | 18 |
| Figure 25 Close up of a HVJB .....  | 18 |
| Figure 26 BEB HV subsystems diagram .....   | 19 |
| Figure 27 Regenerative braking process .....  | 19 |
| Figure 28 BEB HV identification model .....   | 21 |
| Figure 29 Novabus Model of HV locations on a BEB .....  | 22 |
| Figure 30 Overall Proterra cooling loop system flow diagram .....                                       | 26 |
| Figure 31 Battery Coolant Loop Diagram .....  | 27 |
| Figure 32 Power EMP electronics coolant loop diagram .....  | 28 |
| Figure 33 BEB expansion tanks .....   | 28 |
| Figure 34 Example BEB coolant temperature sensors located on a Proterra bus .....                       | 29 |
| Figure 35 BEB coolant loop filters .....  | 29 |
| Figure 36 Diagram of a BEB CAN system .....   | 30 |
| Figure 37 Key electronics on the BEB CAN system .....   | 31 |
| Figure 38 Image of a MUX system .....   | 32 |
| Figure 39 Breakdown of sample ESS configuration and specs .....   | 34 |
| Figure 40 HV battery systems and locations .....  | 35 |
| Figure 41 Diagram of Battery Pack Pin Out .....   | 36 |
| Figure 42 Battery Management Controller example .....   | 37 |
| Figure 43 Example of an Isometer .....  | 38 |

*COURSE: BATTERY ELECTRIC BUS FAMILIARIZATION*

Figure 44 HV exposure icon light on Driver Cab display ..... 39

Figure 45 Typical HVIL layout diagram ..... 39

Figure 46 Example Cab or Driver display ..... 40

Figure 47 Battery Thermal Management System diagram ..... 41

Figure 48 BTMS Line Diagram ..... 41

Figure 49 Preventive Maintenance sample charts for traditional buses and BEBs ..... 42

Figure 50 Preventive Maintenance sample charts for traditional buses and BEBs ..... 43

Figure 51 Examples of New Flyer Traction motor and grease fittings..... 43

Figure 52 HVAC unit under weekly PM ..... 44

Figure 53 Battery pack and traction motor under monthly PM ..... 44

Figure 54 Low Voltage Distribution Box ..... 46

Figure 55 Diagnostic powertrain dongle and NEXIG interface tool ..... 47

Figure 56 SAE Standards for BEB ..... 50

Figure 57 Ohm's Law Relationship Triangle (courtesy of Power and Beyond.com) ..... 52

Figure 58 Watt's Law Relationship Triangle (courtesy of Electrical Volt.com)..... 52

Figure 59 Common electrical schematic icons ..... 53

Figure 60 Example HV warning labels..... 55

Figure 61 Effects of HV on the body..... 55

Figure 62 Inverted pyramid of safety responsibility ..... 56

Figure 63 Diagram of a thermal runaway event – courtesy of Mitsubishi Electric ..... 59

Figure 64 NFPA 70E Limits of Approach and approach values for AC and DC - courtesy of Immersed Technologies ..... 62

Figure 65 Example Arc Flash Warning Label ..... 64

Figure 66 Manual Service Disconnect diagram with location..... 66

Figure 67 Illustration of basic MSD process ..... 67

Figure 68 High Voltage Interlock System relationships example ..... 67

Figure 69 Simple HVIL diagram of defroster..... 69

Figure 70 Passive Propagation Resistance inside a battery cell ..... 70

Figure 71 Sample LOTO Equipment..... 70

Figure 72 Vehicle Operator ..... 74

Figure 73 Roadside Maintenance crew..... 74

Figure 74 Emergency Responder..... 74

Figure 75 Road Supervisor ..... 75

Figure 76 Examples of typical PPE worn during BEB maintenance..... 77

Figure 77 Insulated glove ratings chart..... 77

Figure 78 Electrical hazard rated shoes – courtesy of Carhartt ..... 78

Figure 79 Manual glove inflation inspection ..... 79

Figure 80 Sample glove inflator ..... 79

Figure 81 Approved tested stamp for gloves ..... 79

Figure 82 Example digital multimeter ..... 80

Figure 83 Digital multimeter in use ..... 81

Figure 84 Multimeter test verify test process ..... 81

Figure 85 Clamp-on current probe..... 82

Figure 86 Rescue hook (shepard's hook) ..... 82

Figure 87 ABC-rated fire extinguisher ..... 82

Figure 88 Phase rotation meter ..... 83

*COURSE: BATTERY ELECTRIC BUS FAMILIARIZATION*

Figure 89 Illustration of a safety barricade ..... 83  
Figure 90 Sample insulated tool kit ..... 84  
Figure 91 High Voltage insulated mat – courtesy of COBA Europe ..... 84  
Figure 92 Major BEB manufacturers..... 91  
Figure 93 Overhead charging in use example..... 92  
Figure 94 Example of a wireless charging bus ..... 92  
Figure 95 Primary logo for SAE standards for charging ..... 95  
Figure 96 Example pantographs for charging..... 96  
Figure 97 Diagram of an inductive charging bus..... 97  
Figure 98 Plug-In communication system diagram ..... 98  
Figure 99 Examples of transformers ..... 100  
Figure 100 Example switchgear..... 100  
Figure 101 Wiring diagram of transformer to switchgear ..... 101  
Figure 102 Diagram of model smart charging depot ..... 101  
Figure 103 Example models of smart charging depots - courtesy of ABD ..... 103

# MODULE 1

## *Battery Electric Bus Overview: Fundamentals*

### Outline & Learning Outcomes

- 1-1 Overview
- 1-2 BEBs vs. ICE vs. Hybrid Buses
  - 1) Compare and contrast differences and similarities between BEBs and other current bus types
  - 2) Explain the general advantages and disadvantages of each propulsion type
- 1-3 Details of BEB Systems and Components
  - 1) Describe the process of power flow on a BEB
  - 2) Identify the components and subsystems that make up a standard BEB
  - 3) Describe the primary function(s) of each subsystem and component in the overall process of BEB operation
- 1-4 BEB High-Voltage, System Cooling, and Data Communications
  - 1) Identify the areas of high voltage risk associated with each subsystem of a BEB
  - 2) List the BEB subsystems that utilize a coolant loop
  - 3) Explain why various subsystems utilize a coolant loop
  - 4) Describe the communication protocols on a BEB
- 1-5 Battery Management & Cooling
  - 1) Describe ESS/battery makeup and how to identify them
  - 2) List the battery safety systems and devices
  - 3) Describe the purpose and operation of Battery Thermal Management System [BTMS]
- 1-6 Maintenance
  - 1) Identify the purpose of preventive maintenance
  - 2) List the typical tasks and maintenance intervals for BEBs
  - 3) Differentiate between maintenance tasks on BEBs vs. traditional buses
  - 4) Identify typical diagnostic equipment
- 1-7 Summary



## *COURSE: FAMILIARIZATION TO BATTERY ELECTRIC BUS*

This module gives an overview of what a BEB is, what the similarities and differences are between them and traditional bus types, a review of the common components and their functions, a review of risk assessment and high voltage awareness, battery management systems, and an overview look at preventive maintenance for BEBs. Following the completion of this module, the participant should be able to complete the outcomes with an accuracy of 80% or greater.

**We have opted to include both Proterra and New Flyer as our manufacturers for this course, primarily due to the availability and location of their current bus fleet. We advise you to check out other bus manufacturer models, as they likely will have slight variations or model-specific items to address that you may not see covered in this section.**

## 1-1 OVERVIEW

In order to properly service, maintain, and troubleshoot a vehicle, you first need to know how to identify the parts and processes that help a vehicle to operate. That is the goal of this course: to help you familiarize yourself with the makeup and components of a Battery Electric Bus (BEB). This course will also introduce you to the internal and external processes that help make a BEB function, along with additional knowledge on safety features and equipment and new charging technologies.



*Figure 1 Technicians performing maintenance on a BEB*

A note to participants: Not every agency will have the same bus manufacturer or model as demonstrated in this course. Please consult your manufacturer’s manual and agency’s specific guidelines when it comes to working with a BEB. Each agency may have a variation of names for a specific tool and can vary from agency to agency.

### Terminology

Before we get into the major components of a BEB, let’s take a look at some BEB terminology. Below you will find a table of some common terms:

|  |  |                                 |
|--|--|---------------------------------|
| ABS – Anti-Lock Braking System         | AC- Alternating Current                  | BEB- Battery Electric Bus       |
| BMS- Battery Management System         | CAN- Controller Area Network             | DC-Direct Current               |
| ECU- Electronic Control Unit           | EMI- Electromagnetic Interference        | ESS- Energy Storage System      |
| HV- High Voltage                       | HVIL- High Voltage Interlock Loop        | HVJB- High Voltage Junction Box |
| IGBT-Insulated Gate Bipolar Transistor | ICE BUS – Internal Combustion Engine Bus | LOTO- Lock-out/Tag-out          |
| LV- Low Voltage                        | MSD- Manual Service Disconnect           | MUX- Multiplexing               |
| TM- Traction Motor                     |  |                                 |

Don’t worry if you can’t remember all these terms here at the start. You will be able to see these across the course and pick up on it quickly!

## Brief History of Electric Vehicles

Practical electric vehicles have actually been around for quite a while, dating back to nearly the 1890s if you can believe it! In fact, by the early 1900s the world was introduced to the first ever hybrid model electric vehicle. While these were one of the first types of vehicles to appear, limiting factors such as range and durability, high costs, and lower overall speed led to a general dismissal of such electric vehicles in favor of vehicles featuring the more appealing **internal combustion engine** (ICE) during the early to mid-1900s. ICE vehicles dominated the worldwide market up until the turn of the 21<sup>st</sup> century, where new challenges such as rising oil prices and increasing interest in environmental concerns, such as global warming and alternative fuel sources, provided a stronger platform for the electric vehicle to begin making a comeback.

## What is a Battery Electric Bus?

First, let's determine what is a BEB is. A BEB is an abbreviation for a "**battery electric bus.**" This term applies to a bus that is driven by one or more electric motors that utilize the energy from the onboard high voltage batteries. The BEB design stems from a technological response for a need to reduce greenhouse gas emission, utilize renewable energy, increase fuel economy, and offer a quiet operation.

In general, **high voltage** [HV] is categorized as anything receiving **50 volts** or more. To run a typical BEB, common voltages are between **400 and 800 volts**, meaning that BEBs are already running at voltages well beyond what is considered dangerous. However, BEB designs are also built with redundancy in mind to offer multiple fail-safes in case of the event that you come across HV while working on or troubleshooting a BEB. The design of most components is actually quite similar to other bus designs currently in use or being produced. Most components in this list will feature the axel, suspension, brakes, and steering. We will dive more into the specific BEB components in Section 1-3.

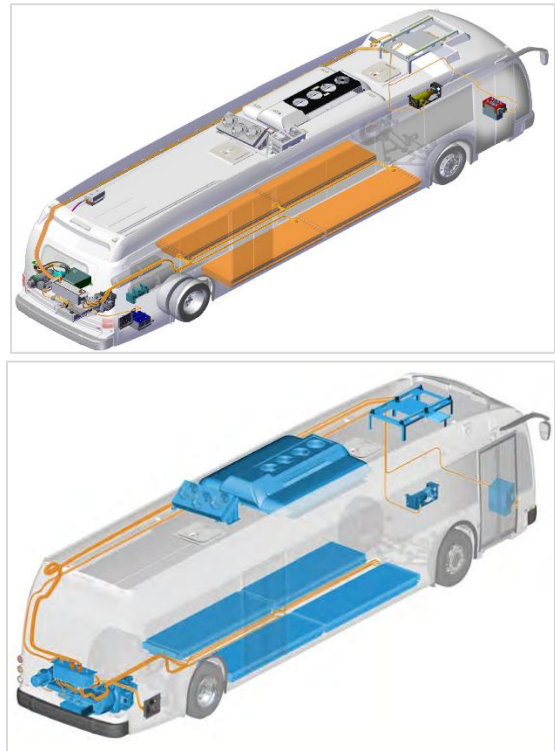


Figure 2 Vendor diagrams of a Battery Electric Bus

## 1-2 BEBS VS. ICE VS. HYBRID BUSES

### Vehicle Characteristics & Operations

Simply put, BEBs are vehicles powered by an electric motor and high voltage batteries, while internal combustion engine [ICE] buses will rely on burning and converting fuel to create translational mechanical energy via pistons. Hybrid buses operate in a similar manner to ICE

buses but will utilize *both* a traditional internal combustion engine along with an electric propulsion system.

Now let's see how BEBs are *similar* to traditional buses.

- The air system and power steering systems are one such similarity. For the most part, these are the same pneumatic and hydraulic components as on traditional buses, with the only difference being that they are electronically driven on a BEB. The axles are also standard, but the difference with a BEB is that the rear axle likely has different gearing.
- Regarding the low voltage system, both BEB and traditional buses use a 12V and 24V system that are similar to other low voltage systems used in transit vehicles. The exception is that the DC-DC converter takes the place of an alternator.
- Grounding is very similar to the same concept you've either worked with or would have knowledge of, so grounding of the low voltage system is similar to previous designs. Some buses have composite bodies that require grounding of the low voltage system through large gauge wires and bus bars. The ground of low voltage system will always be separate from the negative side of the high voltage system.
- Multiplexing (MUX) and I/O systems are similar to what you've seen before, however there's more software control and less physical latter logic. Then, there's the cooling system. Most cooling systems utilize the 50-50 ethylene-glycol mixes, and on a BEB there is no difference. However, BEBs will utilize electric coolant pumps rather than mechanical, and they'll have up to three separate coolant loops.
- On suspension, the front rear suspensions are nearly identical to current designs.
- Your brakes (the pneumatic brake systems)—whether disk or drum assemblies and currently on the axles—do not change.
- Your controller area network (CAN) principles remain the same and there are currently no changes.
- Regarding the doors and ADA equipment, the doors are transit standard pneumatic or electric units, and the ADA equipment does not change at all. The ramps and securements are exactly the same as what you've seen before.



Figure 3 BEB air system

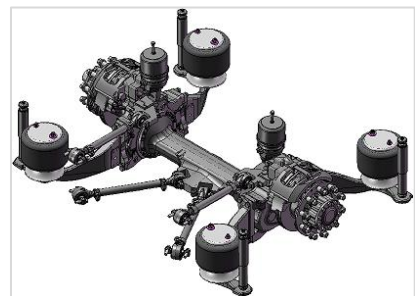


Figure 4 BEB suspension

Next, let's distinguish how some BEB systems *differ* from traditional buses.

## COURSE: FAMILIARIZATION TO BATTERY ELECTRIC BUS

- The first thing that we can look at is the powertrain. The powertrain on a BEB uses power from the energy storage system (ESS) to move the bus through an inverter, supplying 3-phase AC power to a traction motor. Then, there are the high voltage batteries. The high voltage batteries replace the need for onboard fuel.



*Figure 5 BEB Powertrain*

- HV batteries & battery management systems are going to be required to safely control the high voltage batteries on the bus, so the ESS. These systems include enabling and disabling the packs, cooling as well as fault management.
- For charging, BEBs can have both overhead and/or depot charging methods, or a bus may use only one system or the other. These charging methods are unique to the industry and are only going to be needed on a BEB. More on this in Module 3.

As you can see, there are actually quite a few similarities between traditional bus types and BEBs than you may have expected, with only a few major differences to find between these types of buses!

### Standards & Charging

For a brief introduction, with standard BEB charging you have several options. The first is a common method for charging a BEB will be **overhead charging**, or pantograph charging. Next is **plug-in charging**, and the third major method is **inductive charging**.

There are a number of standards that come into play with dealing with BEBs. The most commonly quoted standards are the ones that we're looking at here, and these are contact or plug-in. Standard shop connections are there to allow for mixed OEM fleet deployment, but what we're looking at for most of the connections here are:

1. **J1772** – This is a standard plug-in (currently most common depot application in North America). Provides communication and charging connections in one form.
2. **J3105** – This is an overhead charging standard, which applies to any of the conductive overhead charging or the pantograph charging we covered. Typically, it is a fixed charger arm that moves into position and couples with the bus.
3. **J2954-2** – This covers the inductive or contactless charging.

There is also standard **J3068**, but this is actually more for AC charging and not very applicable currently.



Figure 6 Primary SAE standards for charging

### Plug-In Charging

This is another type of infrastructure you will likely find in a transit agency, and is likely the method of charging you are familiar with or will see utilized currently in many agencies. With plug-in, you are using a charging station with a physical plug receptacle that connects and interacts with the charging receptacle on the bus. This does need to be conducted manually, but it does come with safety features installed to ensure safe operation while interacting with the charger. Plug-in charging can also be commonly referred to as “depot charging” just like overhead charging can, even though pantograph chargers can be located in a depot or on-route.

### Overhead Charging



This is the currently the most common method of BEB charging, and the type of infrastructure you will likely find in a transit agency. With overhead, the infrastructure will include a charger and a charge post or dispenser. The two types are:

1. The roof-mounted pantograph charging also known as “bus-up” (Figure 7 left)
2. The inverted pantograph charging, also known as “bus-down” (Figure 7 right)

The roof-mounted overhead charging method allows for the option to install more powerful chargers for faster charging times. An important note is that HV is not present in the system until

the “handshake” between charger and vehicle is complete. Both of these options utilize SAE standard J3015 (more on charging in Module 3).

No matter which version of pantograph you have installed, the design of this method allows for both on-route and depot charging options. On-route charging is a style of charging where the bus can charge itself by having the battery recycle its power supply using in-motion processes to convert energy into voltage to charge the battery packs. This method allows the buses to stay charged and in operation longer, increasing efficiency and reducing the need to return for charging. Depot charging is a term for having external (manual) charge ports and having your bus(es) return to the garage after a route. Depot charging may also be commonly referred to as “plug-in” charging.



Figure 7 Overhead charging units

**Inductive Charging** - Inductive charging is a method that allows for both on-route and depot charging options. In this method, windings are built into the road(s), which generate an

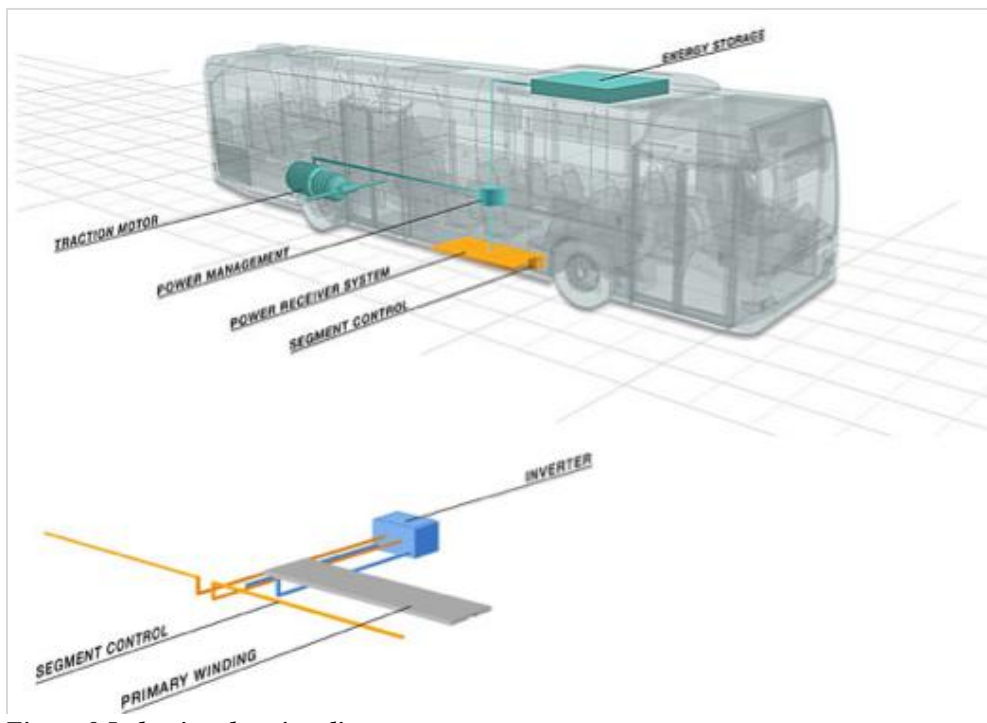


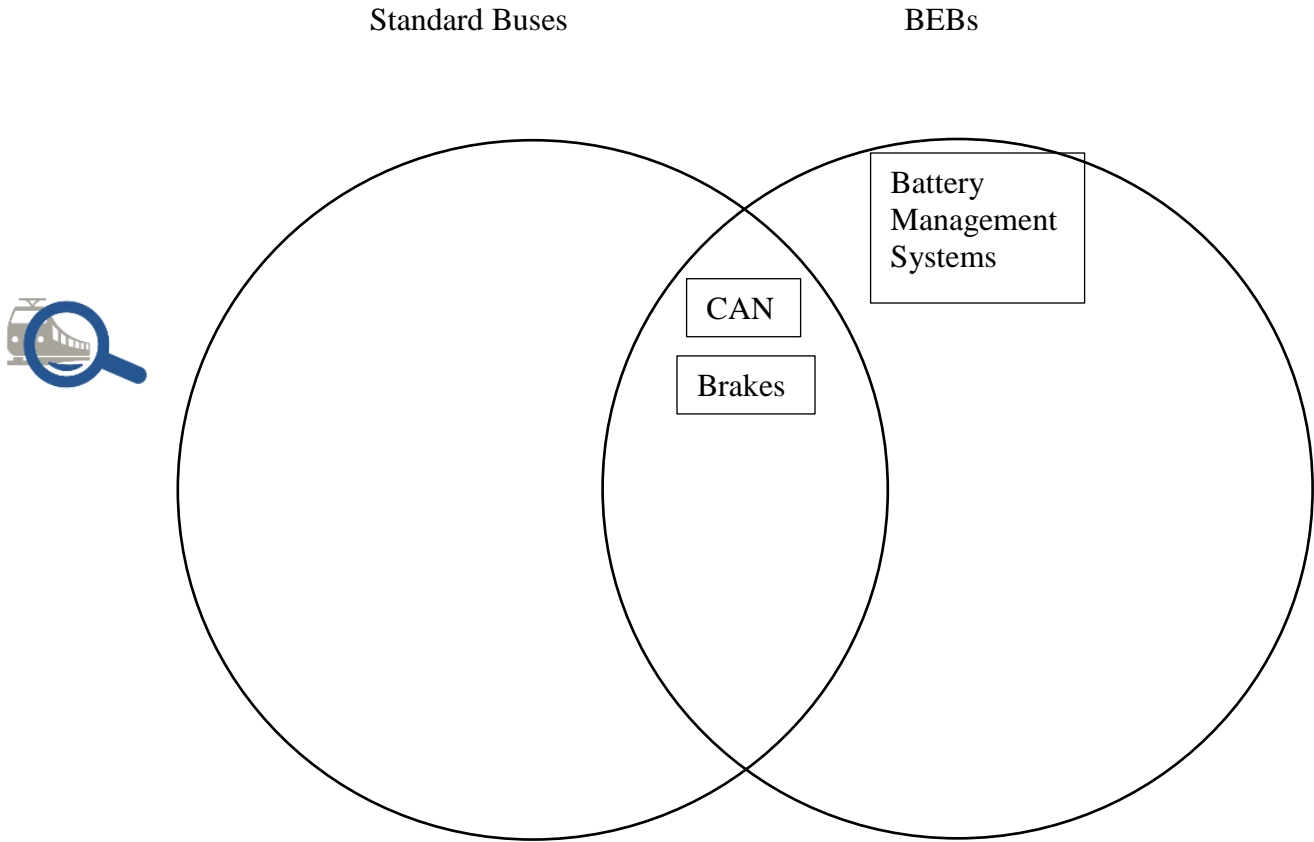
Figure 8 Inductive charging diagram

electromagnetic field. A receiver under the floor of the bus will convert the electromagnetic field into a viable energy that can be supplied throughout to charge the ESS or the high voltage batteries.

This is very similar to the inductive charging technology used to charge most modern cell phones, but on a much larger scale. Keep in mind that inductive charging is a currently emerging technology continuing to be refined. Thus, it is not common in current transit applications, so you may not see this often or at your agency. More on this in Module 3.

### Learning Application 1A

For this exercise, let's review similarities and differences between BEBs and traditional buses. Using this Venn diagram or using a separate sheet of paper as needed, draw and/or fill in the Venn diagram below. The left circle will be titled "Standard Buses" and the right circle will be titled "BEBs."



---

## 1-3 DETAILS OF BEB SYSTEMS AND COMPONENTS

As mentioned in Section 1-1, some commonly similar features of both BEBs and traditional bus types include the axle, suspension, brakes, and steering functions. However, let's now take a look at the components that are unique to a BEB and their functions in the overall process of running a BEB. Compressors and pumps are typically driven by the accessory belt. BEBs however, use the energy stored in the ESS to power a traction motor, which is connected to the drive axle. In any instance where a subsystem was driven by an accessory belt on a diesel bus, an appropriately sized electric motor is used to drive that accessory. When the ESS has depleted its charge, it is recharged



through a dedicated charging system that is connected to the local power grid. This will be your manual overhead or inductive charging (more on this in Module 3).

The following section can be reviewed prior to examining the bus in the shop with your instructor. Once you review the section and your instructor is ready, have the document “Hands-On Exercise 1B – Components” ready. This document will help you review the BEB components introduced in the following sections.

This will be an active learning/walkthrough of a Battery Electric Bus at your location. During this walkthrough your instructor will identify and point out the components on a BEB that were introduced. While at the bus, please make sure that you are able to see the instructor and the components demonstration.

## High Voltage vs. Low Voltage Electrical Systems

What moves a BEB forward? In general, it’s a traction motor connected by a drive shaft into the rear axle differential. Then the battery will automatically receive charge flow from the charger port connection.

- Traction Motors Use Two Levels of Electrical Energy
  - **Low Voltage – Control** (*manages thought processes*)
  - **High Voltage – Movement** (*reacts to control side decisions*)
  - Two separate systems working together

Low-voltage on a transit vehicle is generally 12/24VDC. It will be powered by lead-acid or AGM batteries to get 24V system voltage. Next, the high voltage side on a transit vehicle is generally in the 650-750-volt DC range at the battery before being converted into multi-phase AC high voltage (which is used to turn the traction motor and do work). Identifying these high voltage components such as a traction motor or converter is critical to working safely and managing risk. Figure demonstrates a diagram for this process.

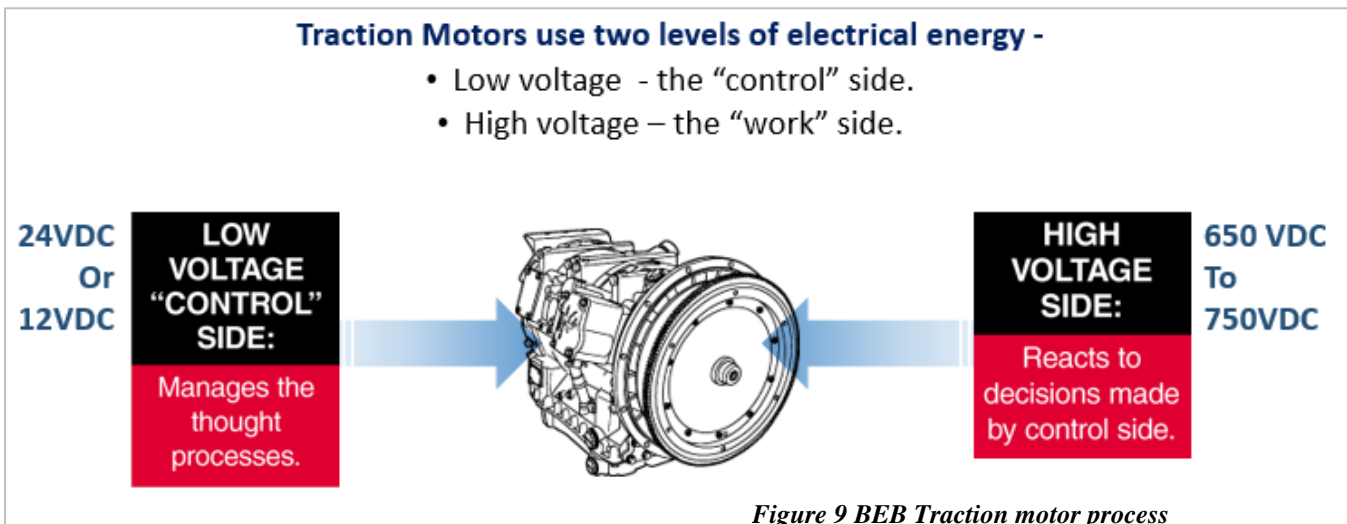
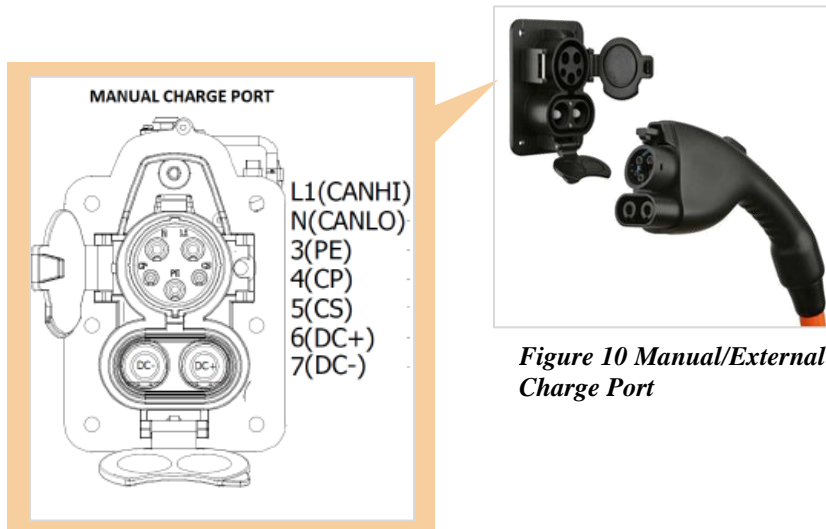


Figure 9 BEB Traction motor process

## Major Components

### 1. External (Manual) Charge Port –

You will find a manual charge port on a BEB. We will discuss how high voltage batteries use energy throughout the bus, so this part will go over how we can refuel the bus. With BEBs, there are multiple methods for recharging the bus. To start we will look at the **manual charge port**. This port is used to connect the depot's installed charging equipment to the bus. This allows for controller area network [CAN] communication between the vehicle charge controller and the charging equipment. The manual charge port utilizes SAE J1772 CCS type 1 standard configuration, with a maximum output of 150 kilowatts. We will describe charging technologies and procedures in Module 3.

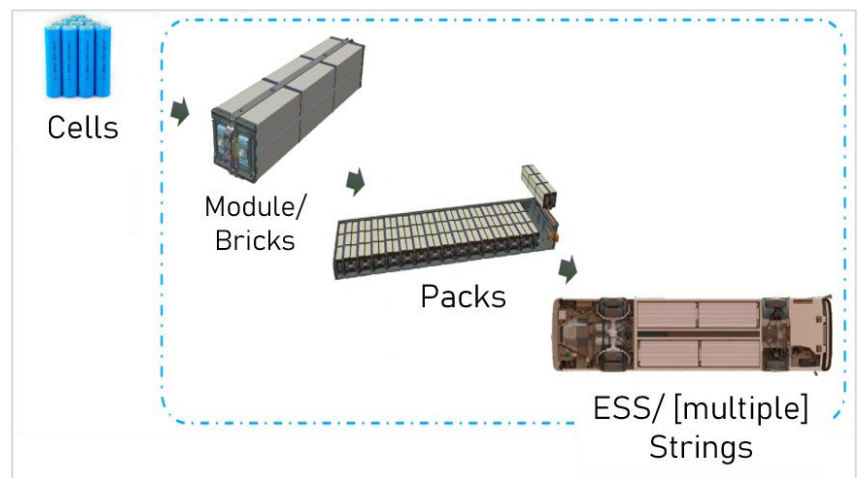


*Figure 10 Manual/External Charge Port*

### 2. Energy Storage System (ESS)

*Figure 11 ESS Makeup diagram*

An **Energy Storage System (ESS)** is a component comprised of the high voltage batteries that power the bus as well as various controllers. In an ESS, cells populate bricks, which populate packs connected together to create strings. Think of the ESS as the equivalent to onboard fuel, whether it be diesel, hydrogen, or any other fuel cells you may be familiar with. The high voltage battery packs are located in various areas of the bus, depending on the bus model and manufacturer, though the most common areas will be located under the floor, side panels, or even the rooftop.



### 3. High Voltage Junction Box [HVJB] -

You will find a high voltage distribution box (or high voltage junction box) [HVJB] on the BEB. In this case, both terms are interchangeable and will vary based on your agency. The HVJB is used to safely distribute the high voltage from the ESS to various high voltage components and subsystems found on the bus. The HVJB contains fuses, contactors, voltage sensors, and current sensors, which allows for complete control of high voltage energy. Access to the HVJB does require special personal protective equipment [PPE] and training.



Figure 12 Example location of HVJB

### 4. Inverters -



Inverters are used to change the DC voltage stored in the high voltage batteries to 3-phase alternating current [AC]. The AC voltage is supplied to an electric motor to generate movement. BEBs will have multiple inverters to perform different tasks, such as powering an air compressor, HVAC, or turning the traction motors.



Figure 13 BEB Inverters

In the right figure you can see two circuits displaying a diagram of inverters in action. DC flows in one direction, while AC flows actually in both directions. Traction motors are going to be AC, as AC is more efficient and the motors can be produced for a

lot less than a DC motor. DC is a straight line at a certain potential, while the AC is a sine wave that changes in voltage value, and it changes in polarity as well (which will invert in every cycle).

The multiple phase AC current, which depends on the motor that the OEM uses, can have three or more phases. In this case, the current will come in every 120 degrees of that sine wave, and the inverter will provide that.

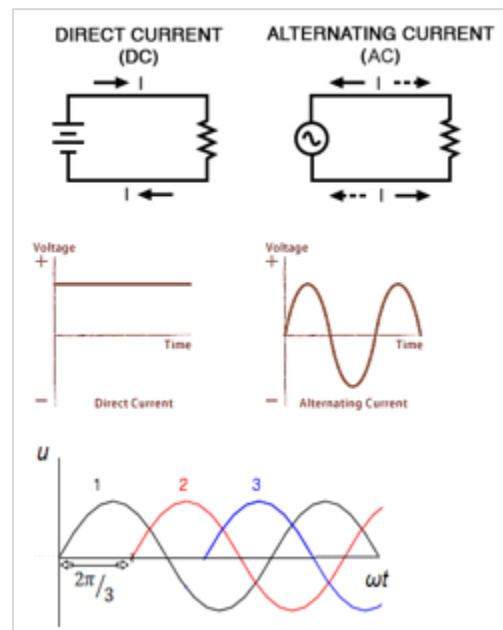


Figure 14 Diagram of alternating current in an inverter

### 5. DC/DC Converter -



Figure 15 DC to DC converter

The DC-DC converter is a liquid cooled component used to change high voltage DC to low voltage DC (“step down” HV). These converters charge the low voltage batteries and supply low voltage power when the high voltage system is enabled (think of these as the “alternator” of the bus because the DC-DC converter replaces the need for an alternator) Converters are also required on a BEB and can have a maximum output upwards of 270 amps. BEBs may have multiple converters depending on the low voltage load and the efficiency of the converters installed. These converters also monitor the HVIL circuit (more on this later) and ensure HV cable integrity.

## 6. Electronic Controllers - & Contactors/Electrical Switching Device



Figure 17 Electronic Controller

Various controllers are used throughout the bus to monitor and control the high voltage and low voltage power. They help to ensure the safe operation of all subsystems on the bus. Some examples may include the vehicle controller, battery management system, the ABSECU, or even the HVAC controller.



Figure 16 Electrical Switching Device

Contactors are also required on BEBs to control the high voltage energy. A contactor is an electrically-controlled switch used to switch electrical power in circuits that have higher voltages and amperages than a typical switch or relay can handle. On BEBs, low voltage power (either 12volts (V) or 24V) is used to control the high voltage switching function of the contactor. Think of contactors as the high voltage equivalent of low voltage relays and switches, with the difference being that they contain special provisions for arc control not found in typical relays and switches.

## 7. High Voltage Cables

These cables are used to convey all of the high voltage energy from the ESS to various high voltage subsystems on the bus. HV cables will always be covered in orange insulation tubing, or looming, and they will also always be separated from low voltage cables to prevent electromagnetic interference [EMI].

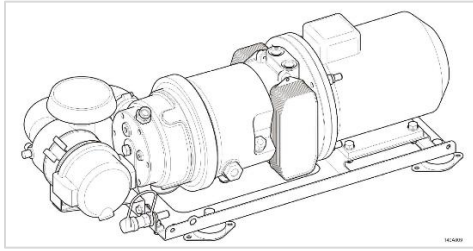
## 8. Electric Drive Accessories/Subsystems (that utilize HV energy from HV Batteries)

These components are featured within your auxiliary subsystems. They include power steering, air compressors, and HVAC systems.

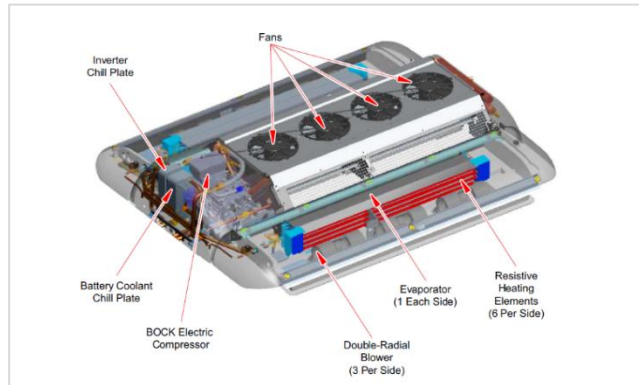


Figure 18 HV Cables

The air compressor is a device that forces air under pressure to convert it into potential energy that can be stored for later use, primarily as a coolant when used in vehicles (in this case a BEB).



**Figure 20** Water cooled rotary vane with an AC motor diagram and drive motor – courtesy AC Transit



**Figure 19** BEB HVAC breakdown diagram

On a BEB it would be a water-cooled rotary vane coupled with an AC motor. Similar to the air compressor, the BEB HVAC unit is also used to heat and cool systems on the bus. The location will vary from manufacturer to manufacturer, but it will typically reside within a rooftop HV location.

## 9. Traction Motors



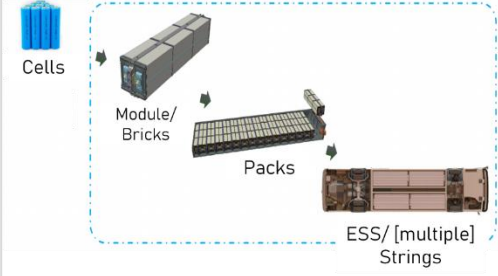


The traction motor uses AC voltage from the inverter to generate torque to turn the wheels. On a BEB, it replaces the traditional diesel engine. Current BEB designs may have up to 3 traction motors on articulating vehicles. There are many different variations. Some may be direct drive, while others may use a transmission to better control the efficiency of the traction motor.




**Figure 21** Midsection of a BEB Traction motor - courtesy of AC Transit

Learning Application 1B

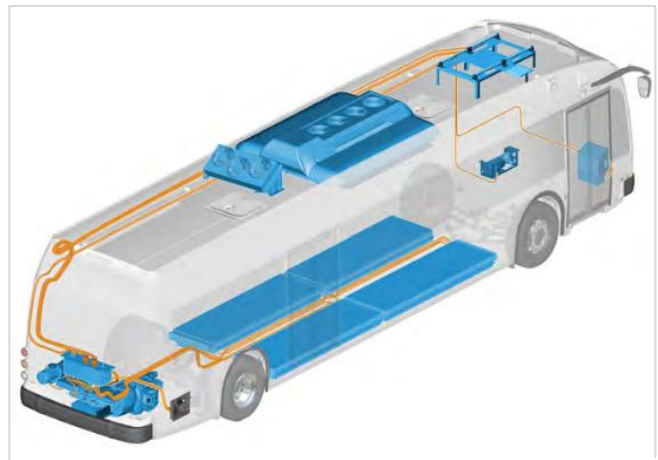
Using the table below, identify and write in the names or function and fill in each blank. You may also find another participant to practice/quiz you on how many you can write/fill in.

| Component  | Function   | Image  |
|--|--|--|
|  | <p>This port is used to connect the depot's installed charging equipment to the bus. This allows for controller area network [CAN] communication between the vehicle charge controller and the charging equipment.</p> |    |
|  <p>Energy Storage System (ESS)</p> |  |  |
| <p>High Voltage Junction Box [HVJB]</p>  |  |  |
|  | <p>A liquid cooled component that used to change high voltage DC to low voltage DC ("step down" HV). These converters charge the low voltage batteries and supply low voltage power</p>                                |  |

|  |  |  |  |
|--|--|--|--|
|  |  | when the high voltage system is enabled.   |  |
|  |  | Used throughout the bus to monitor and control the high voltage and low voltage power. They help ensure the safe operation of all subsystems on the bus. |  |

**Theory of Operation: Power Flow - This section may be covered before going to examine the bus**

Let's take a look at how the process of power flow operates on a BEB. For a typical diesel bus, power generated from the engine is transferred to the axle, then to the wheels through the torque converter. Compressors and pumps are typically driven by the accessory belt. BEBs however, will use the energy stored in the ESS/traction motor to power a traction motor, which is connected to the drive axle. In any instance where a subsystem was driven by an accessory belt on a diesel bus, an appropriately-sized electric motor is used to drive that accessory.



*Figure 22 BEB diagram clear*

When the ESS has depleted its charge, it is recharged through a dedicated charging system that is connected to the local power grid. This will be your manual overhead or inductive charging, as described earlier.

**Inverters & Traction Motors for Power Flow**

Next, let's look at how the inverters operate in the process. For example, we may have a simplified battery and a traction motor diagram. The Insulated Gate Bipolar Transistors (IGBT) in the inverter can be represented as switches. The 3-phase inverters switch high voltage DC energy on and off to create an AC waveform.

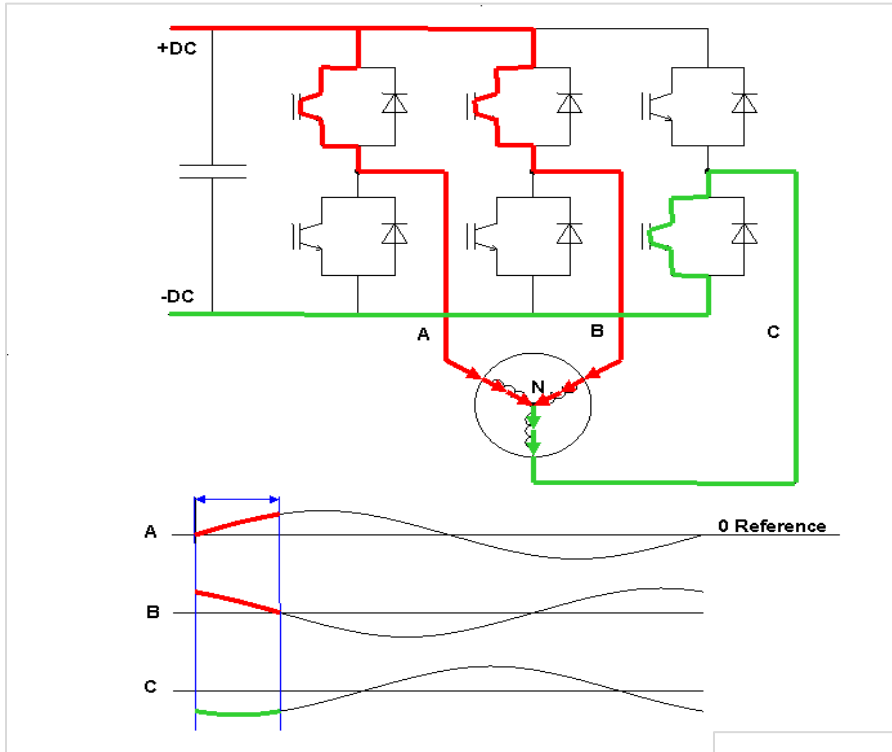
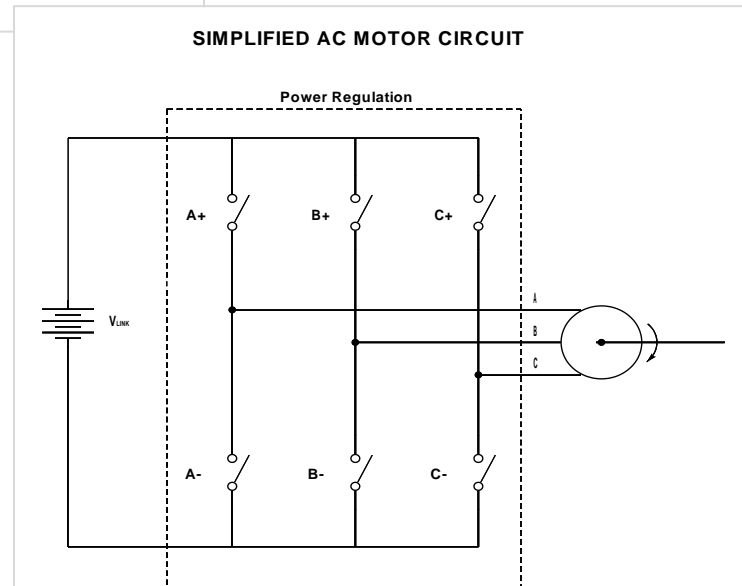


Figure 23 Power flow inverters diagrams

This example diagrams shows how that signal is generated. Essentially, you are switching on two phases —whether it be two positive phases, or two negative phases—but **never a positive and negative of the same phase at the same time**. The reason being: if you were to turn on both at the same time, you create a direct short, and that will not supply any power to the traction motor. The positive and negative IGBTs of each phase **must not** be switched on at the same time, or it will cause a direct short condition.





Once you know how the AC power is being supplied from the inverter, we need to look at how the traction motor creates movement. An AC motor works by applying alternating current to stator windings, which produce a rotating magnetic field in the rotor.

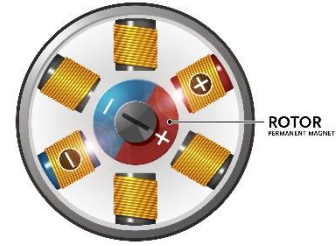


Figure 24 Model of a traction rotor

In order to turn the rotor inside the traction motor, power is supplied to the coils to generate a magnetic field in each. To continue the rotation of the rotor, the pattern needs to alternate. The rotor will then start to follow the rotating field and stator windings due to the magnetic attraction. Inherently, the rotor turns at a slower speed than the alternating magnetic field of the stator, and we refer to this as “slip.” Remember, no “slip” means no current, which means no torque. Cooling is essential for proper operation and will be introduced later on.

### Overall Power Flow

Zooming out a bit, let’s review the actual power flow. Starting off, after initial safety checks are performed by the controllers, the contactors inside the high voltage batteries are commanded closed to supply power to the high voltage system.

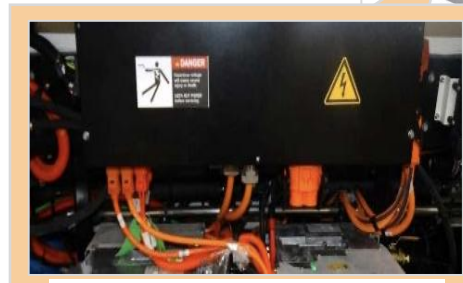
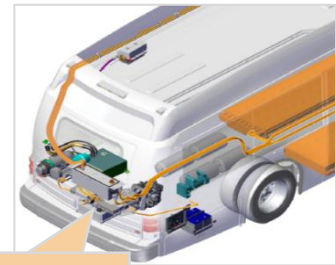
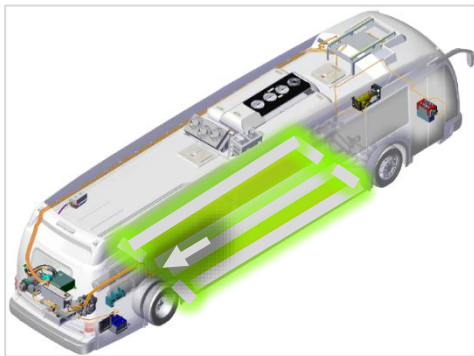
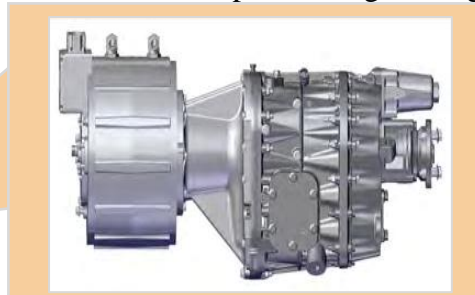
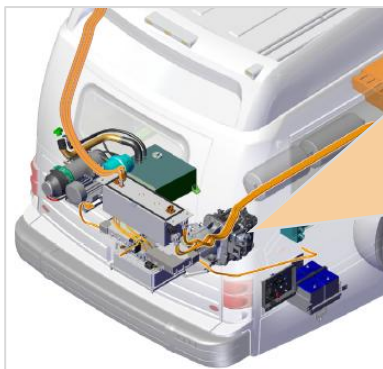


Figure 25 Close up of a HVJB

High voltage power from the ESS is sent first to the high voltage junction box [HVJB] for distribution amongst the high voltage subsystems. Remember that the HVJB contains fuses, contactors, and sensors. This is considered the first point of high voltage energy after the batteries.



From the HVJB, high voltage power is supplied to the traction motor and inverted to provide acceleration to move the bus.

The HVJB also distributes high voltage power to various high voltage subsystems. Some of these examples include power steering, HVAC, air compressor, and the battery management system heater and chiller.

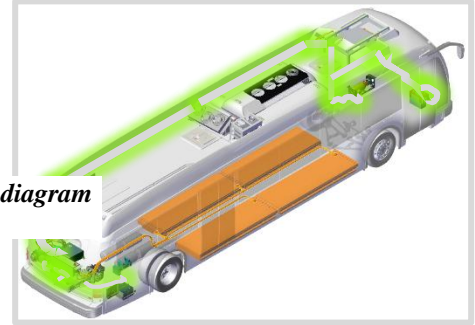


Figure 26 BEB HV subsystems diagram

### Regenerative Braking

Before we take a closer look at the components, let's examine a principle unique to BEBs and hybrid buses: **regenerative braking**. So what is regenerative braking?

Well typically, with BEBs during normal driving conditions, the vehicle causes the high voltage batteries to provide energy to the traction motor, which supplies torque effort to turn the wheels on the drive axle.

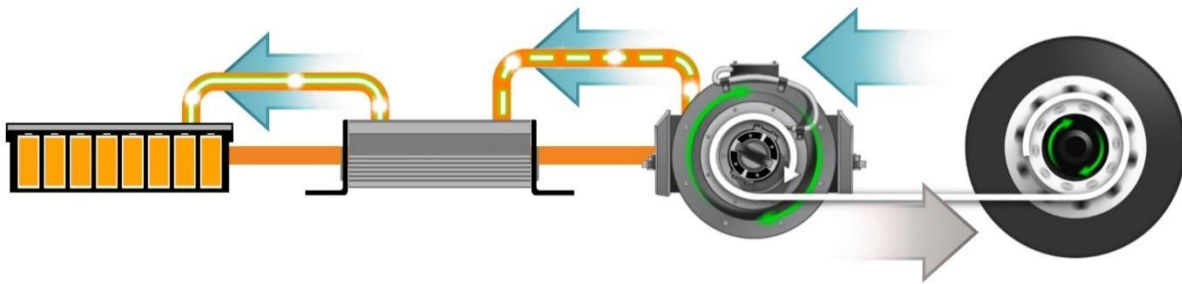


Figure 27 Regenerative braking process

During regenerative braking however (example being coasting to a stop), the flow of energy is reversed. The traction motor then becomes a generator, where the motion of the wheels on the drive axle turns the transmission and traction motor, charging the high voltage batteries and extending the drive time. Regenerative braking undergoes a deceleration similar to that of a traditional retarder. Keep in mind that regenerative braking will stop as soon as the operator reapplies the accelerator, in turn requesting torque from the propulsion system.

It is absolutely vital to a BEB that regenerative braking work efficiently. As mentioned, it is a process that begins anytime the driver starts to reduce acceleration and turns the motor into a generator to try and recuperate that energy. In that regard, it works like a hybrid, as it decelerates and tries to recover some of that power.

Keep in mind:

- **It is not perpetual motion**, but works in conjunction with the pneumatic systems. We are always going to lose more than we're going to recover in this process. Eventually that battery pack is going to be depleted and will need some sort of charging (either on-route, at the depot, etc.)
- With a BEB there is no alternative source to charge the batteries. On a hybrid, there is a diesel engine that can spin a gen set, and on poled trolleys we have an infinite amount of voltage and amperage through the poles. Everything to do with charging and a battery as a non-stationary charge is the result of regenerative braking.

There are things that can affect the regenerative braking. For example, battery temperatures that are too high or low will affect the amount of charge that can be put in the battery. Again, this communication is vital. If the battery is at a high state of charge, or if the battery is already fairly close to being fully charged, you don't want to generate a lot of extra current, because if you generate it you will either have to store it or use it (or else lose that extra charge). We want to make sure that if they are at a higher state of charge we need to reduce regenerative braking. In instances such as towing, you should always pull an axle or a drive shaft, or disconnect the drive motor from the battery packs when towing.

Regen-braking depends on battery state of charge. The following will limit regen-braking:

- High battery temperatures
- Low battery temperatures
- High battery state of charge
- Towing

---

### Learning Application 1C

Using the word bank below, identify and write in which part of the phrase is missing from the sentence. You may refer back to your notes or guide, but try to attempt it without looking back. You may also find another participant to practice/quiz you on how many you can write/fill in.

**Word bank:** traction motor, ESS, never positive and negative together, alternate, contactors, AC waveform, High Voltage Junction Box [HVJB], traction motors, magnetic attraction

1. BEBs however, will use the energy stored in the \_\_\_\_\_, which is connected to the drive axle.
2. In any instance where a subsystem was driven by an accessory belt on a diesel bus, an appropriately-sized \_\_\_\_\_ is used to drive that accessory.
3. The 3-phase inverters switches high voltage DC energy on and off to create an \_\_\_\_ \_\_\_\_\_.
4. Essentially, you are switching on—whether it be two positive phases, or two negative phases—but \_\_\_\_\_.
5. In order to turn the rotor inside the traction motor, power is supplied to the coils to generate a \_\_\_\_\_ in each. To continue the rotation of the rotor, the pattern needs to \_\_\_\_\_.
6. An AC motor works by applying \_\_\_\_\_ to stator windings, which produce a rotating magnetic field in the rotor. The rotor will then start to follow the rotating field and stator windings due to the \_\_\_\_\_.
7. Starting off, after initial safety checks are performed by the controllers, the \_\_\_\_\_ inside the high voltage batteries are commanded closed to supply power to the high voltage system.
8. High voltage power from the ESS is sent first to \_\_\_\_\_ for distribution amongst the high voltage subsystems.



9. From the HVJB, high voltage power is supplied to the \_\_\_\_\_ and inverted to provide acceleration to move the bus bottom.

## 1-4 BEB HIGH-VOLTAGE IDENTIFICATION & RISKS, SYSTEM COOLING, AND DATA COMMUNICATIONS

As with Section 1-2, your instructor may decide to review Section 1-4 before visiting an on-site BEB and having you go through document “Hands-On Exercise 1D – HV Awareness”. This document will help you review the BEB components introduced in the following sections.

This will be an active discussion of risk assessment and hazard identification of typical Battery Electric Bus zones. During this walkthrough your instructor will identify and point out the HV areas located on a BEB that were introduced. While at the bus, please make sure that you are able to see the instructor and hear what they are saying.

### High Voltage Awareness & Identification

It is important to understand where high voltage is present and how to identify it. Like with any other potentially dangerous system, one must assume that HV is present any time you work with any bus or charger circuit. Failure to do so, or relaxing safety protocols, can prove fatal.

Where can you encounter HV in a BEB? High voltage is present in BEBs in the areas associated at these locations:

- Charger
- Battery Pack
- Inverter
- Electric Traction Motor
- DC-DC Converter
- Power Distribution Node
- Compressor
- Electric AC accessories

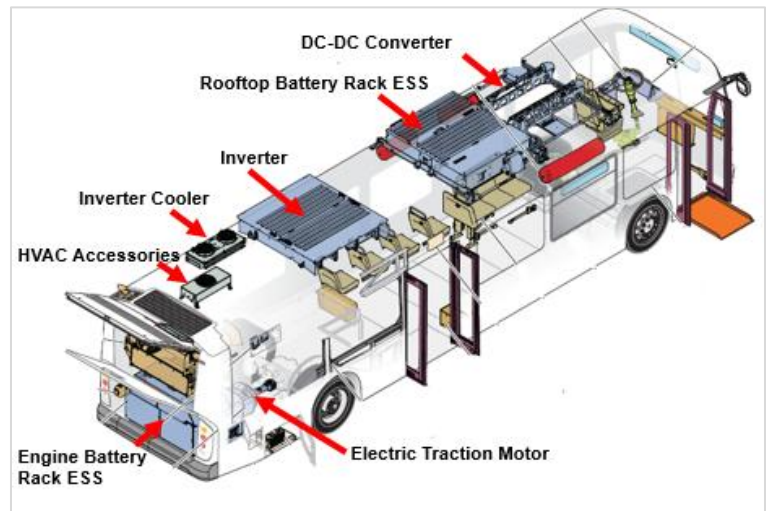
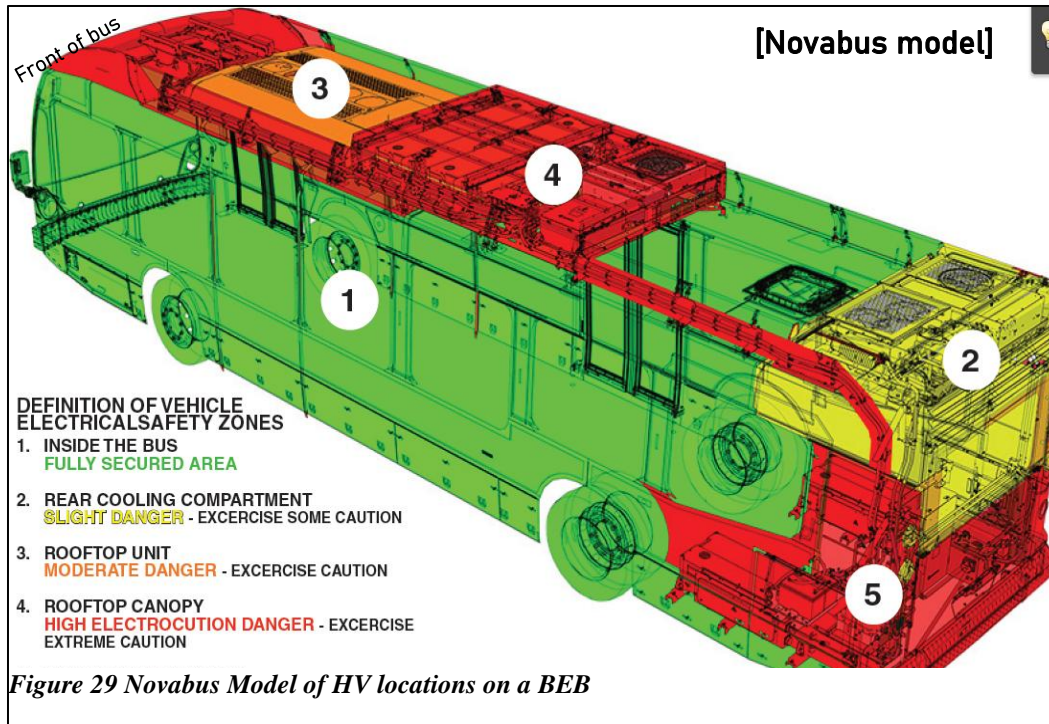


Figure 28 BEB HV identification model



In this model of a 40-foot Novabus BEB (see figure), we can identify areas that are associated with either High risk, Moderate Risk, Slight Risk or Low risk or No risk of high voltage. Area 1 [green] has the lowest to no risk of HV. Areas 2 [yellow] has a slight risk. Area 3 [orange] has a moderate risk, and Areas 4 and 5 [red] have the highest risk or capacity for HV.

### **High Risk (shown in Red):**

It is important to understand that a BEB will have multiple sources of energy. Batteries could have anywhere between 1 and 4 units on a single bus. In this example the batteries are located in the engine bay – two batteries and two on the rooftop as backup (on a Proterra bus they are built into the floor). We have areas like the junction boxes which bring the batteries together with devices like inverters or converters.

- Batteries, between 1 and 4 of them. Located in engine bay and/or roof top or built-into the floor.
- Junction Boxes. Bring batteries together with devices like the inverter or an accessories converter.
- Pantograph rails (front of the bus). The area would be at full 750-volt DC potential.

### **Moderate Risk [Orange]**

Still HV but at a lower potential. On this example bus, it is running 208 three-phase AC to run accessories. Accessories include:

## COURSE: FAMILIARIZATION TO BATTERY ELECTRIC BUS

- Air Compressor
- HVAC
- Steering

### Slight Risk [Yellow]

- Rear cooling compartment; since HV runs through watch the HV cabling/looming

### Low to No Risk [Green]

These will be areas similar to what you are used to working with on diesel buses.

- Low voltage. 12/24 VDC systems.
- Passenger Area
- Driver Area
- Front Axle/Rear Axle
- You can safely do a brake job or grease the axle without HV concerns.

All components containing HV will have a warning label on the box. These boxes are high-risk, and precautions need to be taken as listed in the slide. As a rule of thumb, unless you can confirm it's safe, assume hazardous voltage is present. Follow the safety policies and guidelines, both within your agency and those provided to you by the vendor of the vehicle. Always wear the appropriate PPE or personal protection equipment (more on this in the next section).

- Interconnecting the boxes within the bus are the cables themselves, which All high-voltage cables are identified with large orange sheathing.
  - **The HV cables themselves are well protected.** Layers include the middle conductor (copper), protective sheathing, stainless steel braiding, then another external layer of protective sheathing.
  - We then protect that with stainless steel braiding and finally another external layer of orange protective sheathing. They are very well-built cables, but never repaired—they should always be replaced.
- **High Voltage is NEVER grounded through the chassis.** Each component will have a Positive (+) and a Negative (-) HV Cable.
  - Instead, the return path of any component is through an orange cable.
  - Refer to your vendor specific materials as these designations can vary between manufacturers. Different vendors will label them or tag them in different ways but it's important to know you'll never be grounded through the chassis.

## COURSE: FAMILIARIZATION TO BATTERY ELECTRIC BUS

- High Voltage System and Vehicle 12/24V Systems are separate.
- Isolation between High Voltage and chassis ground is **ALWAYS monitored by ECMs**, and if there is ever a loss of isolation between the high voltage and chassis ground, all energy storage systems are immediately shut down (within milliseconds) through the contactors.

To reiterate, the components that include high voltage are: the battery pack or energy storage system, the inverter, the electric traction motor, any of the DC-DC converters that change DC voltages, any power distribution node or junction box, compressors (these are high voltage AC compressors) and any other AC accessories (AC unit or any of the other AC accessories you have on your bus). When in doubt, follow the safety protocols and assume high voltage is present. The components are obvious nodes for voltage to be present. All circuitry should be considered “hot” (or live). **An analogy to keep in mind: High voltage is like a gun that you have to treat like it’s always loaded.**

Keep in mind: It’s always important to work with your vendor-specific training or maintenance manual(s) to identify these components because as you might have seen with other buses, the components and system locations can be in different locations depending on the makeup of the bus.

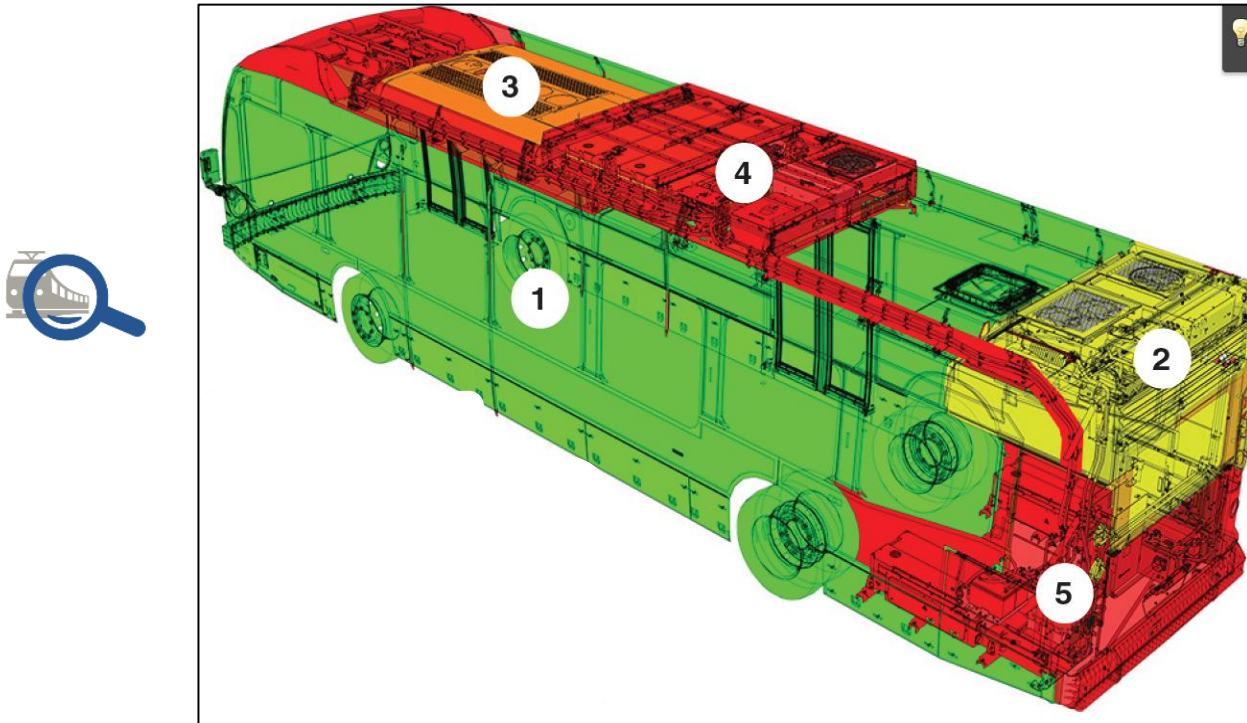
Additionally, make sure to pay attention to any HV safety symbols and warning labels you come across and understand their placement and use! They are there for a reason – do not dismiss. You should always heed safety warnings! These will be used in both literature and on components. They come in different levels (DANGER, Caution, etc.) but will be **clearly identified**. When you see them (manual and on components/vehicle), you need to follow PPE and safety instructions!

There are a few tips and strategies that will help you to be able to identify the presence of high voltage on a BEB:

- **Make sure you’re familiar with OEM manuals and procedures.**
- Check for any large orange cables that you’ll see running in and out of the motor, in and out of the ESS, or throughout the junction boxes, etc. These are most definitely high voltage locations, and you need to make sure you have checked them for voltage before you work on them.
- Point out any labels. Always look out for any of these types of signs, and don’t drop your guard.
- Follow LOTO. This is lockout/tagout procedures, or de-energizing of the bus, when you’re working on the system. Always proceed with caution.
- **Use “live-dead-live” to properly test for voltage**
- Use insulated tools
- Set up barrier(s) around the bus
- **Always assume high voltage is present.** Don’t take any chances. Wear your PPE!

Learning Application 1D -

Review the following image and answer the following questions with your group and instructor:



1. Which areas of the bus are indicated with high risk levels of HV? How were they identified?

2. Discuss how you would identify and assess any risk factor for:

- a. Low to No risk areas of the bus
- b. Moderate and Medium risk areas of the bus
- c. High Risk areas of the bus

3. In the medium to high risks areas, what components have high voltage?



4. Discuss what actions would you need to take to protect yourself in HV areas?

## Temperature/Cooling Systems and Management

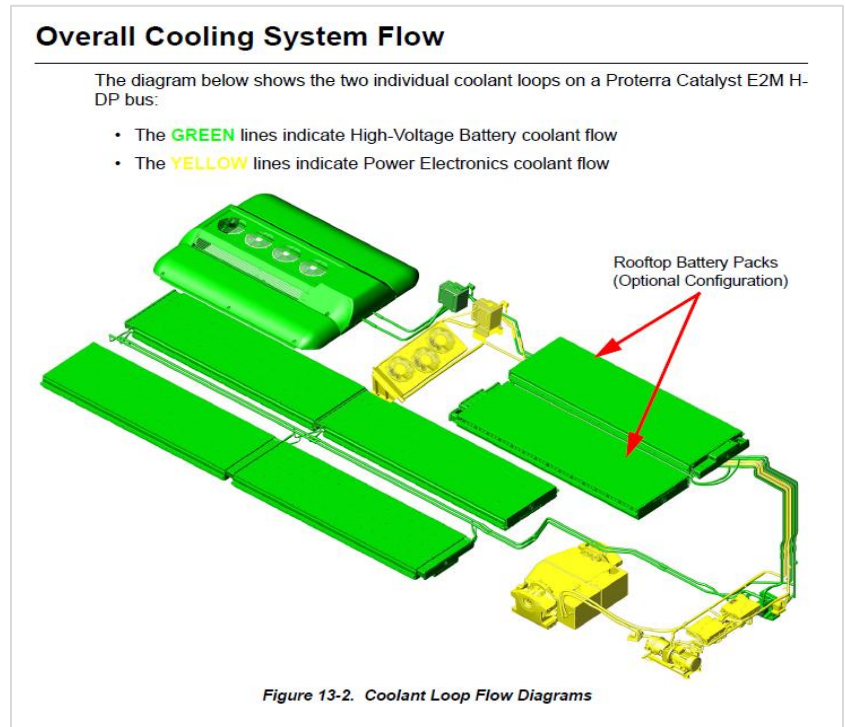
BEBs use many electrical systems, and with use of electricity comes the energy runoff as heat. Because we want to avoid excess amounts of heating (or overheating) within the bus systems and subsystems, we want to have functioning cooling systems to manage the temperature to avoid thermal runaway and other electrical hazards. Having cooling systems and management can also help improve the battery life as systems that operate within the normal temperature range will be able to continue functioning for longer compared to systems without such management.

However, the same might also be said for heating systems and subsystems of the bus. Some locations may experience freezing or colder ambient temperatures, and thus would need the bus and its components to warm up prior to going out into service.

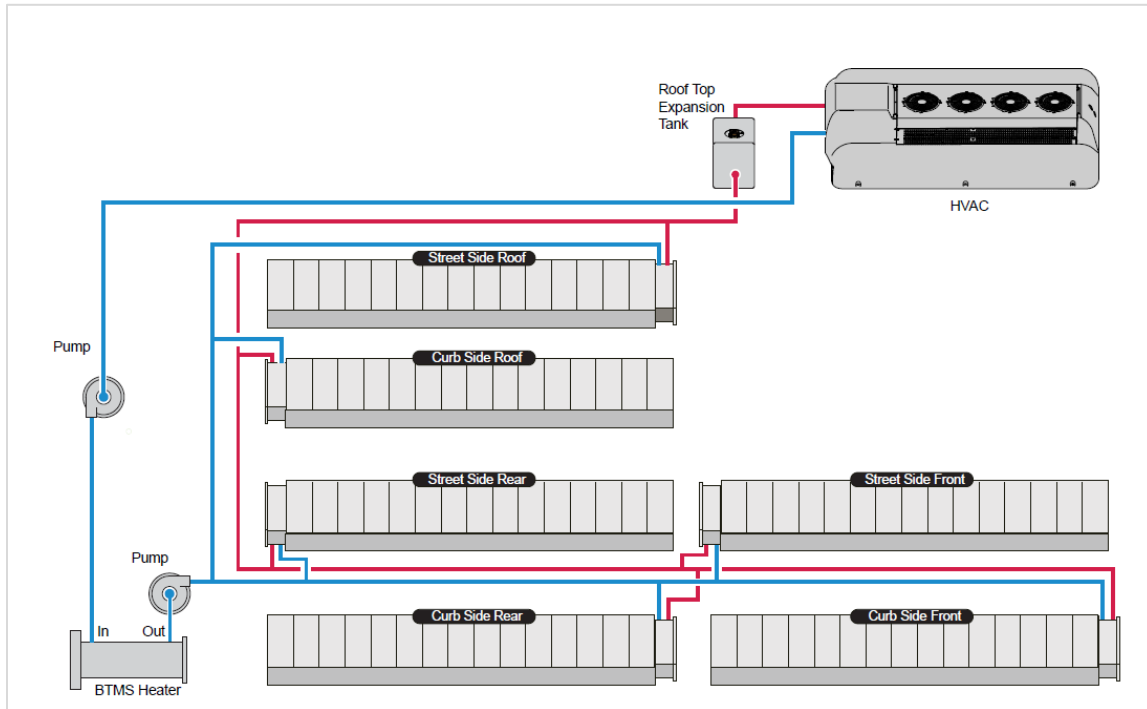
A BEB can utilize two independent cooling loops to cool the high-voltage batteries and the power electronics on the bus, though this is dependent on OEM variations. For this we will review some subsystems that utilize a cooling system, and some maintenance steps that you would take to make sure the cooling management in each system is functioning properly.

### Battery Coolant Loop

The battery coolant loop will provide heat or cooling for all battery packs based on the ambient temperature. A battery coolant loop can have dedicated pumps and an expansion tank located on the rooftop of the bus, or where the battery loop is located (roof, undercarriage, etc.). This is an independent (dedicated) loop that runs into and through the batteries. The ideal operating temps for Lithium ion (Li-ion) batteries is 65-85 degrees. The suggested ratio for the battery makeup is 50:50 ethylene glycol and water mixture.



**Figure 30 Overall Proterra cooling loop system flow diagram**



**Figure 31 Battery Coolant Loop Diagram**

### Power Electronics Coolant Loop

Generally, the power electronics coolant loop is used to cool the traction motor, inverter(s), DC-DC converters and any additional HV electrical component (outside of the batteries) that need cooling. One major factor here is that this specific loop **does not heat any components**.

The power electronics loop also has dedicated coolant pumps that circulate coolant through the power electronics units that require cooling, as well as the cooling module, through a three-fan radiator and then through a strainer to repeat the loop. You may hear the radiator fans on the power electronics loop run for several seconds in reverse to clear any debris that may have settled on the unit overnight. *This description and example is specific to Proterra models and may not apply for your agency OEM (e.g. power steering).*

**BE WARNED** – The radiator fans can start and stop automatically. Please ensure that you keep your hands clear of the rotating fan blades to avoid injury.

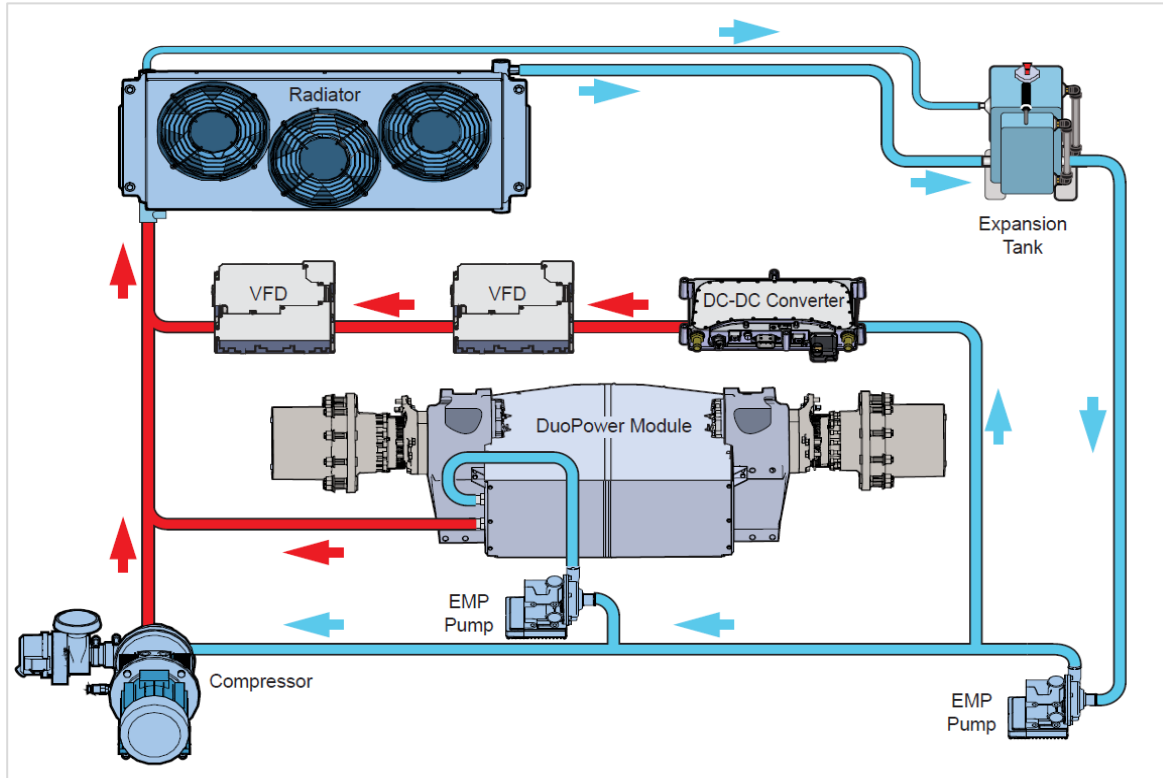


Figure 32 Power EMP electronics coolant loop diagram

### Expansion Tanks

There is an expansion tank on each closed loop systems which is equipped with level sensors to indicate the fill status and solenoids that open or close to allow the expansion tank to fill with coolant and purge air as necessary. To fill the Battery Coolant Loop the Coolant Fill pump (Shurflo pump) transfers coolant from the fill port to the Battery Coolant side of the Expansion Tank on the rooftop. When this tank reaches the fill level, the LED light will turn off, indicating that the whole system is full. There will be at least one tank per loop.



Figure 33 BEB expansion tanks

### Coolant Temp Sensors

The coolant temperature sensors are sensors used to monitor and track the temperature of each independent cooling loop. There will be at least one sensor for each loop, but it is best to keep the coolant full. In the battery coolant loop the data is used to determine if the heater is needed to be turned on to warm the batteries. These sensors will be located in various areas of the bus dependent on manufacturer.

In a Proterra model, these coolant temperature sensors located on the power electronic cooling loops and the battery cooling loops. They are used to monitor the individual temperature of each individual loop. There is a coolant temperature sensor located in the hardline on the inlet side of each EMP pump. Each sensor monitors the temperature of the coolant in that specific coolant

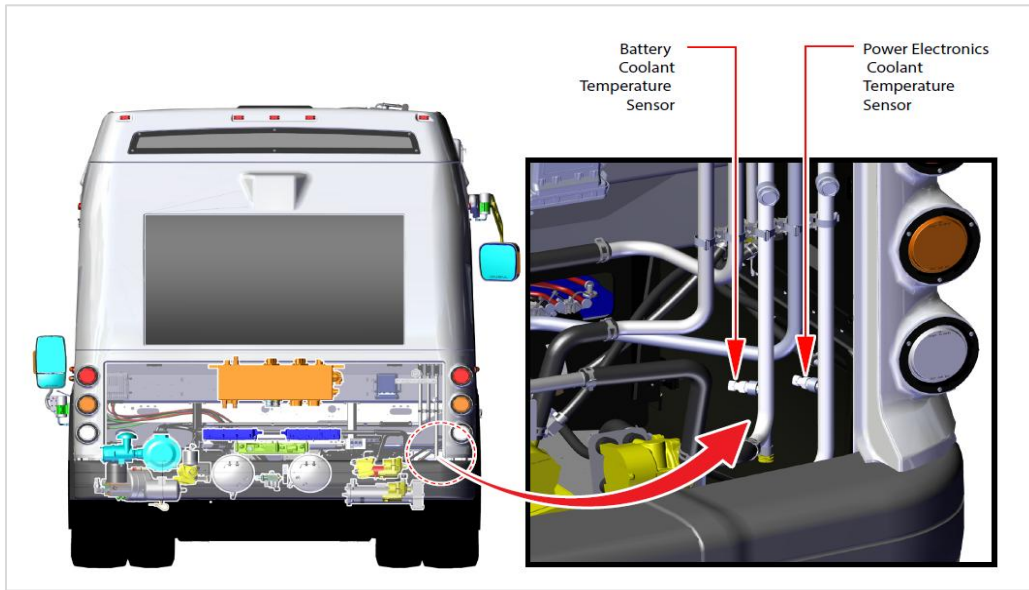


Figure 34 Example BEB coolant temperature sensors located on a Proterra bus

loop. The temperature sensors are accessible by opening the ProDrive trunk lid. Both sensors are located rear CS in the rear of the Pro Drive compartment.

### Coolant Loop Filters

A coolant filter will be a filter for each independent cooling loop that is used to clean and remove dirt/debris from the coolant. At least one filter will be used for each isolated loop.

In a Proterra model, there are two main coolant system filters. One will be located street side and the other is located curbside. Both are in line for each cooling system loop.

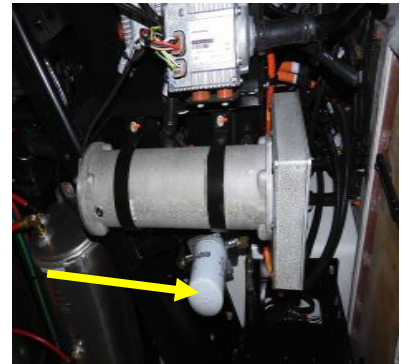


Figure 35 BEB coolant loop filters

## Data Communications Systems Basics

Data communication can be a bit complex, even on a standard bus. With a BEB, let's consider the two primary forms of data communication to get a clearer understanding of how the communication on a BEB functions.

### CAN System for Communication

A controller area network (CAN for short) is a type of serial communications protocol that utilizes standard J-1939 allowing electronic units to communicate and share essential vehicle control data. CAN for BEBs are currently very similar, or even identical to other systems, though the number of CAN networks has increased from previous designs (due to the increase in interacting electrical components and systems).

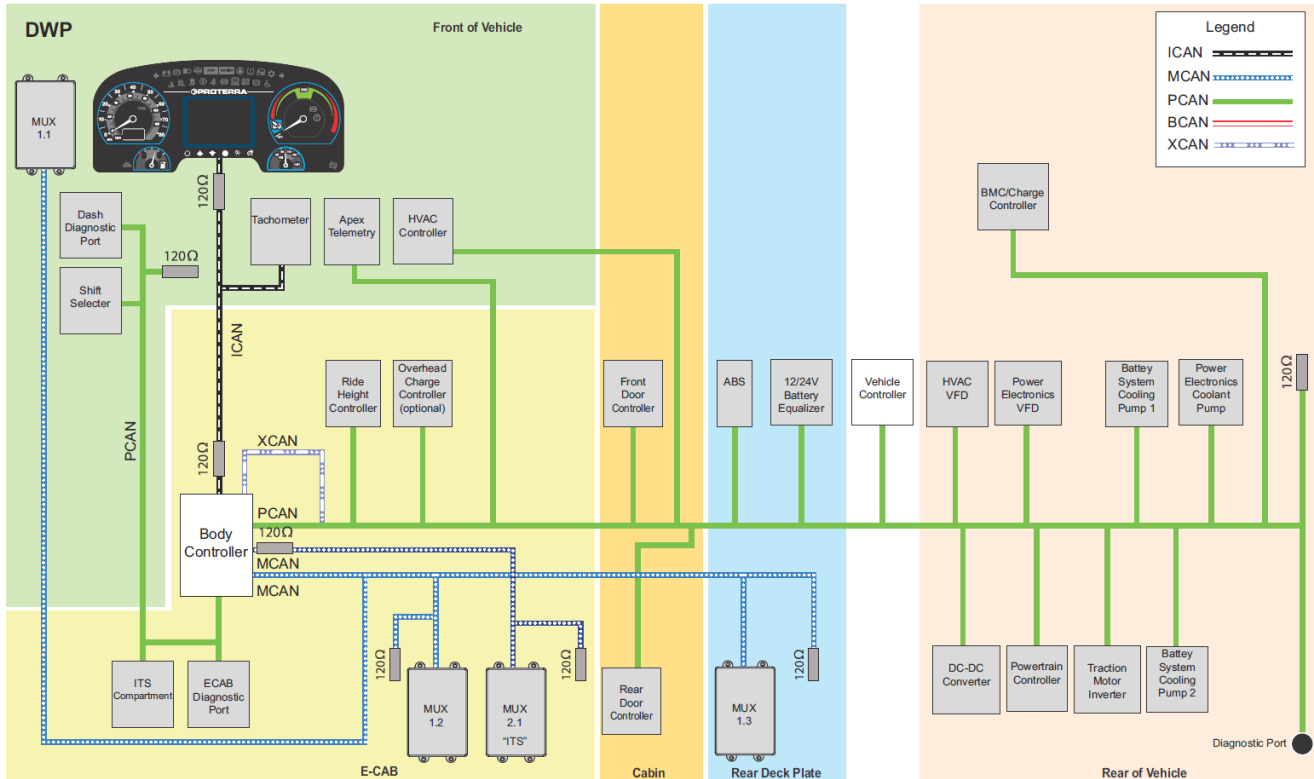


Figure 36 Diagram of a BEB CAN system

Simple CAN messages allow for the reduction of transmissions necessary on the network. All devices on a CAN are able to receive every message transmitted on the network, but the message is ignored by the particular device if it is not relevant. On a BEB we can have multiple different networks, including individual networks in the battery packs acting as a single network. However, these do operate at different bit rates and have differing number of connected devices to avoid overcrowding or miscommunication between networks. The figure above shows an example CAN for a Proterra model bus, so depending on your manufacturer this configuration may vary slightly

CAN devices work by sending and receiving messages through changing the voltage between two lines, pulling one line to a higher voltage (identified as CAN HI) and pulling the other low (identified as CAN LO). The network consists of a main “trunk” line, terminated at each end by resistors between them, with all devices wired in parallel “branches” off of the main trunk line. Both the “trunk” and “branches” are wrapped in a common shield, which is grounded to the chassis for noise protection.

Because CAN devices rely on accurate voltage measurements, it is important to have solid wiring and good clean connections in the network and at the devices. It is also important to have the proper resistance at each end of the network. Some bus manufacturers may use sealed ultrasonic weld splices to join the “trunk” and “branch” for each device to minimize potential corrosion and connector issues. The figure below displays a diagram of this process.

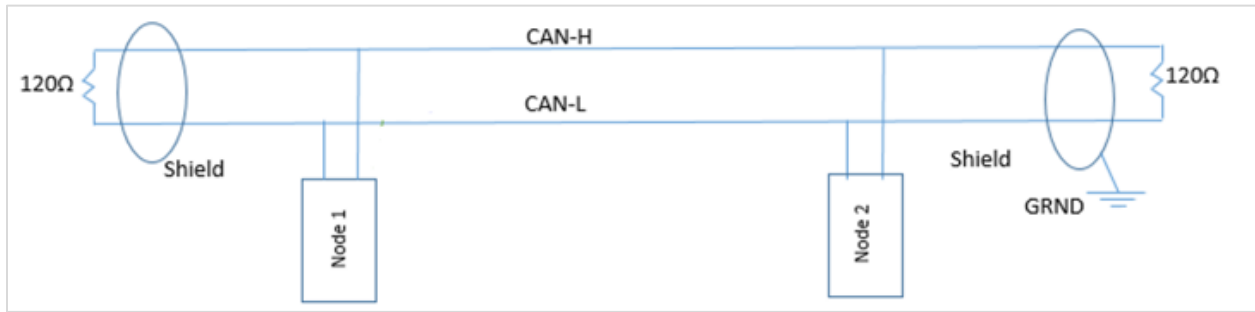


Figure 37 displays a visual of the interconnected relationships between connections in the Control System Architecture.

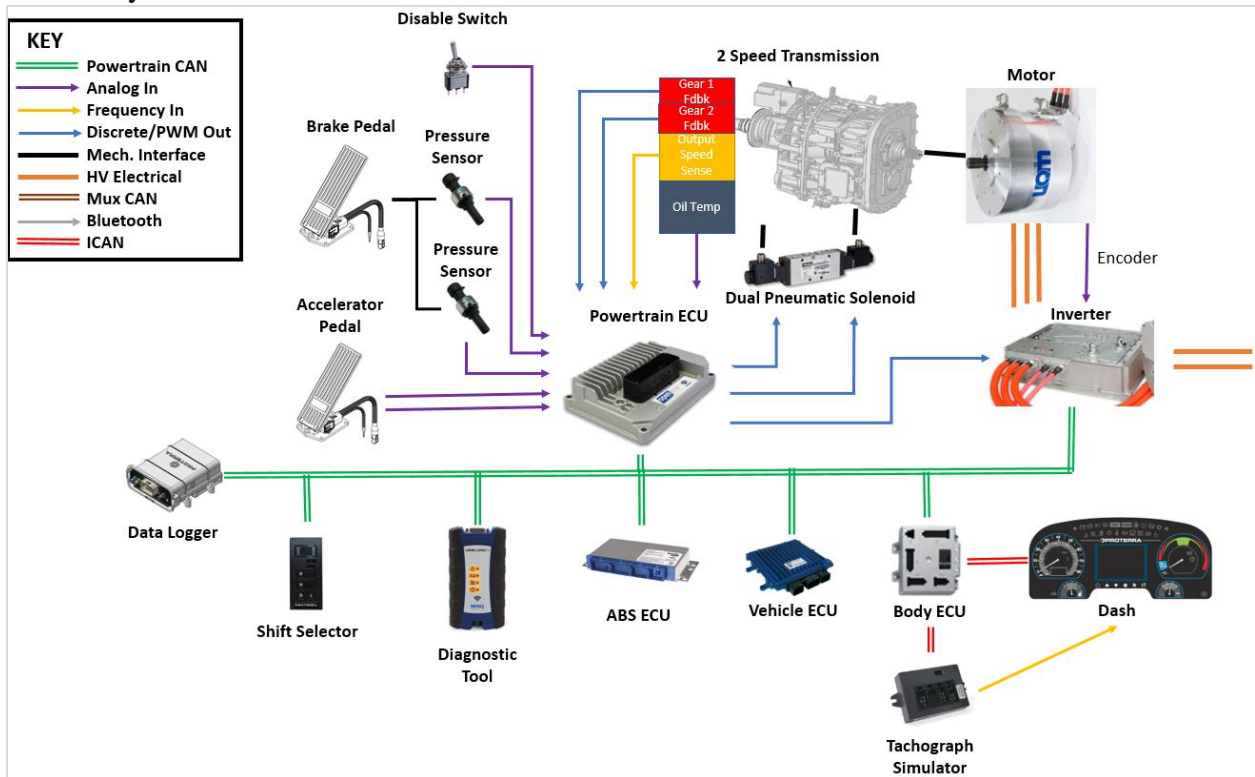
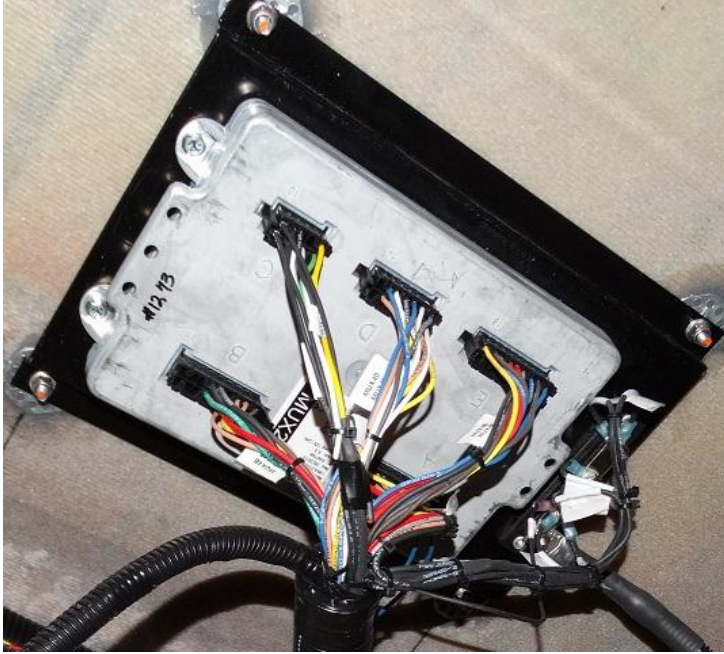


Figure 37 Key electronics on the BEB CAN system

### Multiplexing System

A multiplex system (commonly identified as MUX) is a system comprised of one Main and any multitude of Secondary controllers. This multiplexing program provides intelligent programmed interaction between components rather than mechanical as has been the standard. With MUX, multiple component signals are transmitted simultaneously along a common data bus and are controlled and monitored by a digital microprocessor.



*Figure 38 Image of a MUX system*

Multiplexing simplifies the system by replacing multiple mechanical relays and switches with reliable solid-state components. This solid-state system provides significant advantages over traditional mechanical components and wiring.

The MUX master controller also serves as a centralized troubleshooting tool that simplifies the process of isolating causes of electrical malfunctions without requiring special diagnostic hardware and software interfaces.

### MUX Theory of Operation

As a process, the MUX system can be broken down into the following theory of operation:

1. An **input** is received by a module (from a switch, sensor, etc.).
2. The input acts as a **signal** (of voltage or ground from a switch, sensor, etc.).
3. That module will then send a signal over the communication network to the **other modules**.
4. The other modules are programmed to **act** when they receive a particular command.
5. An **output** is sent as a signal (voltage or ground) from a module to a load or another device.
6. The process continues constantly; every module is constantly in communication with the **other modules**.

## 1-5 BATTERY MANAGEMENT & COOLING

Now let's introduce some fundamentals of the batteries, referred to as the energy storage system (ESS) as described earlier in the module. We will also look at how the particular batteries are cooled. Anytime that a battery is charged or discharged it will generate heat. As such, we need to remove that heat, thus a need for a cooling management system.

One thing to reiterate with our comparisons of BEBs to more traditional models of buses is that this technology — while advancing — is not entirely new. The new part is essentially the actual batteries, and the fact that the vehicles are not running on a wire. Many of the same theories that applied to hybrid buses and other vehicles (like poled trolleys) basically apply to a BEB as well. This is because some of the same parts are being used, just with a more modern perspective.

### Basics on the High Voltage Battery (ESS) Construction

We covered this earlier in the module, but the energy storage system (ESS) can also be called a high voltage battery, or referred to as battery packs. There are likely many names for this across the industry, and OEMs may use different terminology too. For this we will stick to simple terms: strings, cells, packs. All these terms come together to make up what we will refer to as a battery pack.

Every system of a BEB is CAN-related. They are all tied together. The battery packs do have CAN, which will be discussed shortly. Some applications of CAN network may be different, in which some may be private or some may be public. We will also introduce how to identify the packs, as you will need to know which pack is faulting when it happens. As a technician, if you have multiple packs on the vehicle and one of those packs is experiencing a fault, you have to be able to determine which pack is being affected. There are ways this can be done to identify the packs, which is done via CAN.

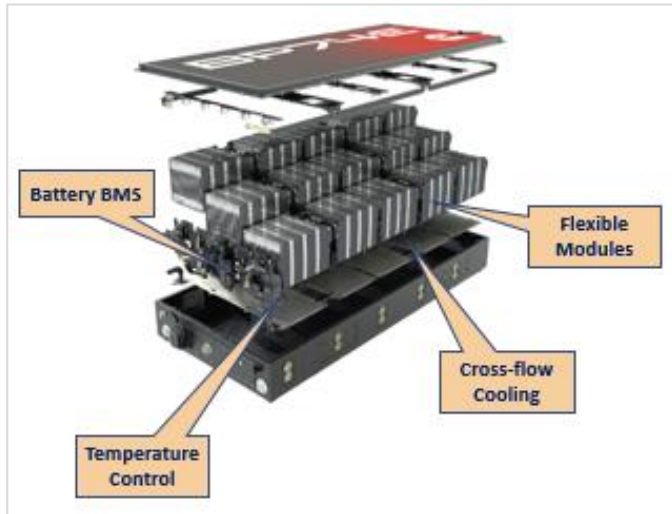
### High Voltage Battery Configuration

As a general rule (but can vary slightly depending on manufacturer) the packs are going to contain multiple cells, producing electricity chemically about 2 volts per cell. Some are a little less, some may be a little more. We will tie those cells in series just like with a traditional 12-volt battery and to achieve 400-800 volts inside that pack. What you need to do is monitor what those packs — or what those cells inside of those packs, strings or any other terms — and monitor how those cells are charging, discharging, temperatures, current voltage level and so forth.

Inside a pack there are multiple low voltage controllers, and those low voltage controllers monitor the battery. One of those low voltage controllers (whatever is designated as the one inside the pack to communicate) talks to a controller called the BMC, which is the **battery master controller** (or main controller). There will be an external controller that will monitor all the batteries and make sure that they are doing what we want them to do (regarding voltage and the availability to charge/discharge, temperatures and so forth). The battery management system [BMS] is a system that keeps the energy storage system or battery packs thermally conditioned and safe. This is crucial for **all** batteries.



Keep in mind that the controllers inside the battery packs are going to be operated at 12 or 24 volts depending on the OEM. It is vital to make sure we have a high voltage to control low voltage. This is typical for a 24-volt system if you are well under 20. However, if you have a 12-volt system and you are well under 10 volts, then you may not get these systems to function the way that they were designed to.



| Sample Battery                  |                                   |
|---------------------------------|-----------------------------------|
| Nominal voltage                 | 400-800 V                         |
| Battery chemistry (electrolyte) | Lithium ion                       |
| Cooling                         | Water and Ethylene glycol (50:50) |
| Capacity                        | 74 kWh                            |

Figure 39 Breakdown of sample ESS configuration and specs

The figure shows a general configuration of an ESS. Modules can be used as another term, but essentially this is made up of multiple cells and held together in a pack, and when tied in a series we will come up with a nominal voltage per pack of

between 400 and 800 volts. This is of course, high voltage, which again is any voltage above 50 volts.

The table provides average specs and data of a sample battery. Most of the batteries have some version of lithium ion (with there being possibly millions of different recipes for lithium ions), but the base chemistry makeup will be the same on all of the packs. In order to cool battery packs, we need to take ethylene and water (with a 50-50 mix ratio) and run this through the packs to keep them cool. Sometimes this may even be used to heat the packs depending on the environment the buses run in. Generically, packs can put out different kilowatt hours, but the ones commonly used on a BEB will put out approximately 74 kilowatts per pack. This will vary by manufacturer, so always consult your OEM manuals for correct numbers.

### Handling High Voltage Batteries

We need high voltage to flow out into the system to accomplish propulsion. There are at least two contactors inside of a pack: a high voltage contactor on the negative side of the system, and a high voltage contactor negative side of the system. Those two contactors have to be turned on, or closed, to let that current flow out of the battery and back to the battery as a path for current. Keep in mind that these high voltage contactors are controlled by low voltage. Again, low voltage is controlling high voltage as part of the safety and thinking protocol.

If you pull a battery off a bus, you will want to avoid the high voltage connection. Once the manual service disconnect (MSD) is disconnected, those terminals should be isolated, so there shouldn't be concern about electrical shock occurring.

There can be different connections going off the batteries, depending on the OEM. This means batteries may be mounted in various locations on the bus. You may see some mounted on the roof, the chassis, or what you might consider the engine compartment. There can be single or multiple packs. The packs store chemical energy to power high voltage devices.

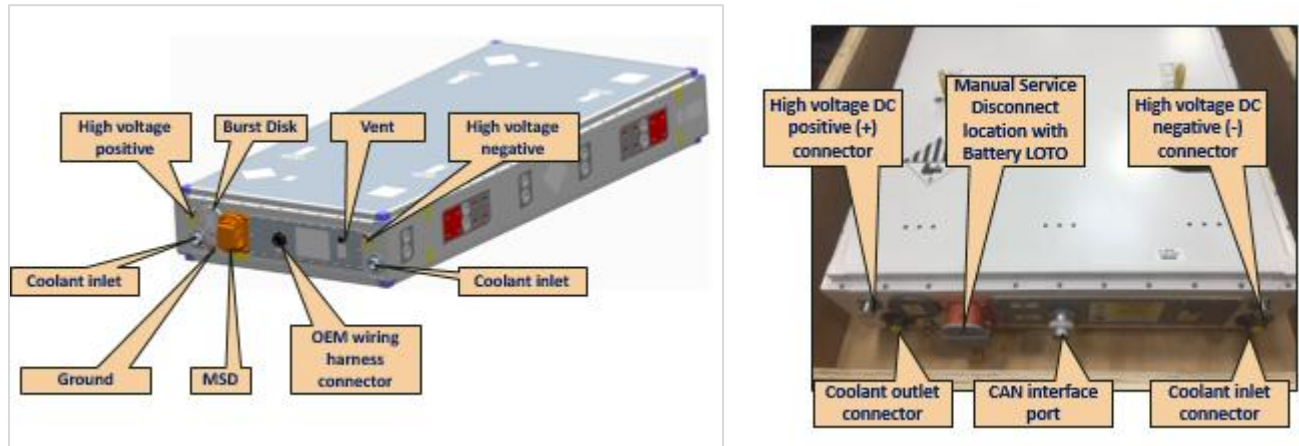


Figure 40 HV battery systems and locations

**\*Keep in mind that these high voltage devices are going to be responsible for supplying low voltage as well\***

As previously mentioned, inverters work by taking high voltage and knocking it down to low voltage, so these battery packs not only need to provide all the power needed for propulsion but also provide all the power needed to run multiplexing systems on the bus and more.

One concept you may be unfamiliar with is “floating power” and “ground the battery only.” What this means is that we aren’t taking any connections from the battery packs or high voltage and connecting to a low voltage chassis or low voltage part. The current flow is from the pack, through the device, back to the pack and not through the vehicle chassis. Other terminology may refer to this as a “hot body,” if voltage did get into the chassis. This is helpful as it does indicate the vehicle is live or powered.

For typical connections on a battery, we need to have a high voltage connection for positive and a high voltage connection for negative. We have to run coolant through the battery, so we will also need to have coolant inlet and outlets. We also need to have a low voltage connection to the battery packs. One of the things people often overlook is that you cannot get high voltage if you do not have low voltage. If the bus batteries are suspect and not working correctly, then high voltage is hard to get online, and it becomes difficult for the batteries to do what is needed for the system to work. We’ll have a low voltage harness and another harness going through that. It is important to note that you should not run low voltage harnesses next to (or wire loom) them to high voltage harnesses due to the electromagnetic fields that can disrupt functioning.

One device we need to keep in mind is known as an MSD. An MSD stands for a “**manual service disconnect.**” The MSD is going to be a way to keep the power generated isolated to that particular pack. If you have multiple packs, and the MSD happens to be on the pack, you will have multiple service disconnect points to worry about, but this is in place to keep you safe. The

last thing to point out is a battery lock out/tag out device, which when you remove the MSD that was install over the connection point, you are safe and not exposed to a high voltage connection.

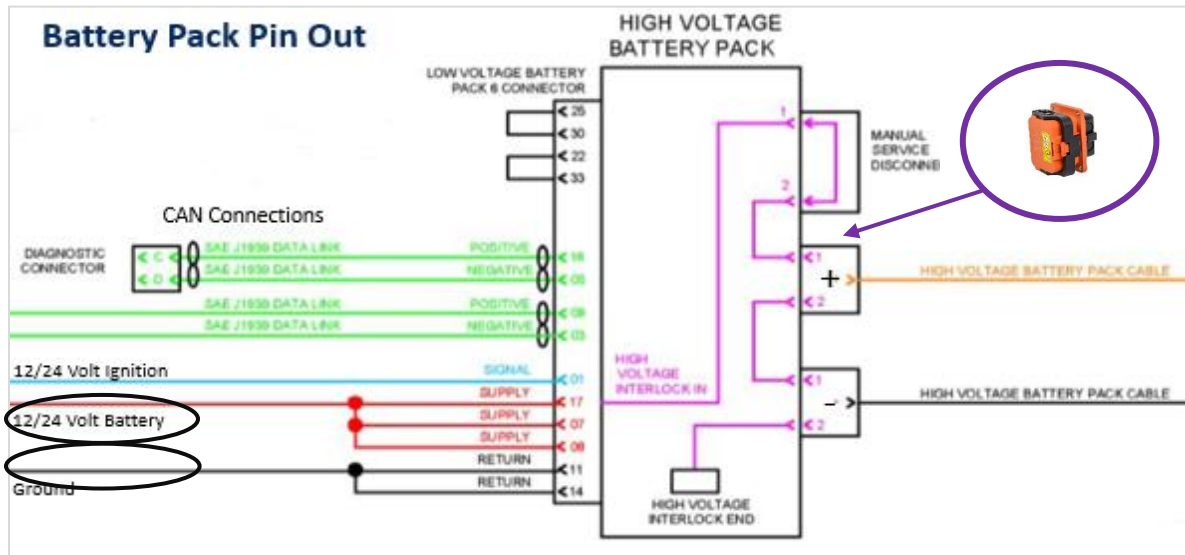


Figure 41 Diagram of Battery Pack Pin Out

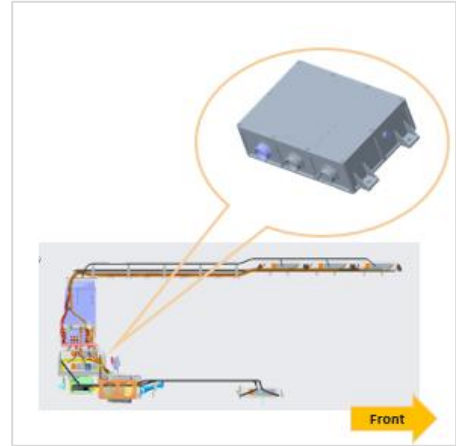
***Be aware that this is a schematic specific to a Gilleg model bus, so you may or may not encounter this type of configuration.***

Figure 41 illustrates some of the low voltage connections that we are making to a battery pack. In the center of the illustration is a 12-volt/24-volt ignition source that comes from either the OEM's multiplexing system or the low voltage electrical system on the bus. This is like any other ignition source-because it will act to be a turn on signal for the pack to initialize.

Just like most electrical parts, you need to have an ignition source and a battery source for that to work correctly. The red wiring underneath the blue wire make up a battery supply voltage. The battery source helps run some of the low voltage internal circuits inside of the battery. Then, we need to a very good chassis ground on the low voltage side, so we provide ground to the controller so it can function. If all this works really well, it should initialize a high voltage and a low voltage contactor, which would enable that battery to be able to supply high voltage out into the system so we can manipulate it. You will find the MSD there at the top. If we were to remove the MSD, this prevents the flow of energy on the positive side of the circuit, which then makes it impossible to allow energy to flow from the battery.

## Battery Management Controller (BMC)

Next, we can briefly mention the **Battery management controller**, or BMC. This system basically runs the whole battery system. It monitors all the batteries, gets that information from the controllers inside of the packs, and then it shares that data with the main system controller so we can read that data for troubleshooting. Some of them are serviceable, and some are not. If they are serviceable, they'll typically have fuses, relays, and a control board inside the BMC.



*Figure 42 Battery Management Controller example*

---

## Learning Application 1E

Using the phrases below, identify and fill in the blanks to write out the procedure for how the theory of MUX operates.

**Word bank:** Signal, output, act, other modules, input, other modules



1. An \_\_\_\_ is received by a module (from a switch, sensor, etc.).
2. The input acts as a \_\_\_\_ (of voltage or ground from a switch, sensor, etc.).
3. That module will send a signal to the over the communication network to \_\_\_\_\_.
4. The other modules are programmed to \_\_\_\_ when they receive a particular command.
5. An \_\_\_\_ is sent as a signal (voltage or ground) from a module to a load or another device
6. The process continues constantly; every module is constantly in communication with the \_\_\_\_\_.

---

## ESS and Battery Safety

### ESS Battery Chemistry

On the battery pack, labeling will always be a great place to start to identifying key safety aspects when working or handling BEB components. It starts with battery chemistry, continues with ESS construction and safety design features, then testing and then engineering controls and monitoring, and finally OEM warnings and guidelines for batteries.

An essential step in knowing safety when dealing with batteries is the battery chemistry. The type of battery chemistry can determine many factors, including safety. Because the battery is essential a mixture of chemical components that create reactions that affect the ability to store and expel energy, knowing how the battery is made up can be a vital safety aspect. Different types of battery chemistry currently include:

1. NMC – Lithium Nickel Manganese Cobalt Oxide
2. LFP – Lithium Iron Phosphate
3. Others: LTO (Lithium Titanite Oxide) and more.

These battery packs will always be well-encased for safety and isolation. They are not easy to get to and eliminate any potential for arc flashing and other concerns, including locked and non-conductive covers, venting and moisture proof. They will have separate posts and will have separate grounding circuits. The battery packs come with monitoring system – for ensuring proper and safe operation and for alarms to alert you if they are overheating or if there is a temperature concern.

The ESS and battery packs have great safety features to prevent incidents. The battery management system (BMS) has the ability to disable and re-enable packs if there is an internal issue. There is also a feature called overcurrent protection to prevent thermal runaway. There are also emerging technologies- such as Passive Propagation Resistance – are adding additional levels of safety. This is a safety feature that acts to encompass individual cells in a battery pack within a specialized foam to act as an isolator between cells.

### High Voltage Isolation Safety & Detection

Another important part of battery safety features inside the battery packs is something known as an isometer. The isometer is a device that helps prevent us from getting exposed to high voltage in the event of a leakage. An isometer can be installed anywhere in a HV circuit (if installed at all). If this isometer sees a problem, it will attempt to open the contactors — both positive and negative — inside the pack and isolate that voltage and amperage to the pack.

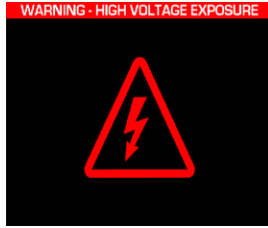
An isometer looks for most of the severe fault(s) that could occur in a high voltage system due to a breakdown in isolation. These can include the following scenarios:

- A coolant leak in a battery pack, possibly in a traction motor, that would also trigger an isolation fault.
- If we have damaged cables, this can detect those damaged cables depending on what the damage is.
- If there is cell leakage
- If the vehicle was in an accident and we go to initialize high voltage, this device is going to look at that and try to shut the system down to keep us safe.



*Figure 43 Example of an Isometer*

If we would see an isolation fault, it will say it measures resistance. It calculates a voltage drop between high voltage positive in chassis and high voltage in negative in chassis, and it compares them to each other to make sure that there is no high voltage leaking into low voltage or chassis parts. Figures will vary by manufacturer, but normal isolation ranges are typically between **250 kilohms (KΩ)** and **50 megaohms (MΩ)**.



As a result, you will get an indicator light on the light bar or in the driver’s area, saying “high voltage exposure” or something of that nature (Figure 44). This lets you know that there is a possibility for high voltage exposure. It is vital that drivers be made aware when they see a high voltage exposure light and what their response should be. This would be covered in training for drivers.

Figure 44 HV exposure icon light on Driver Cab display

### High Voltage Interlock Loop [HVIL] & Driver Display

The next thing designed to help keep you safe is what’s going to be called **high voltage interlock loop**, or **HVIL**. The following figure shows a generic layout of HVIL, and will be featured more in Module 2. HVIL is essentially a low voltage control, and there will be a low voltage controller somewhere in the system (could be multiples, depending on the OEM). That low voltage controller sends out a low voltage signal through a wire and goes through every part through a connection point (such as the HVJB).

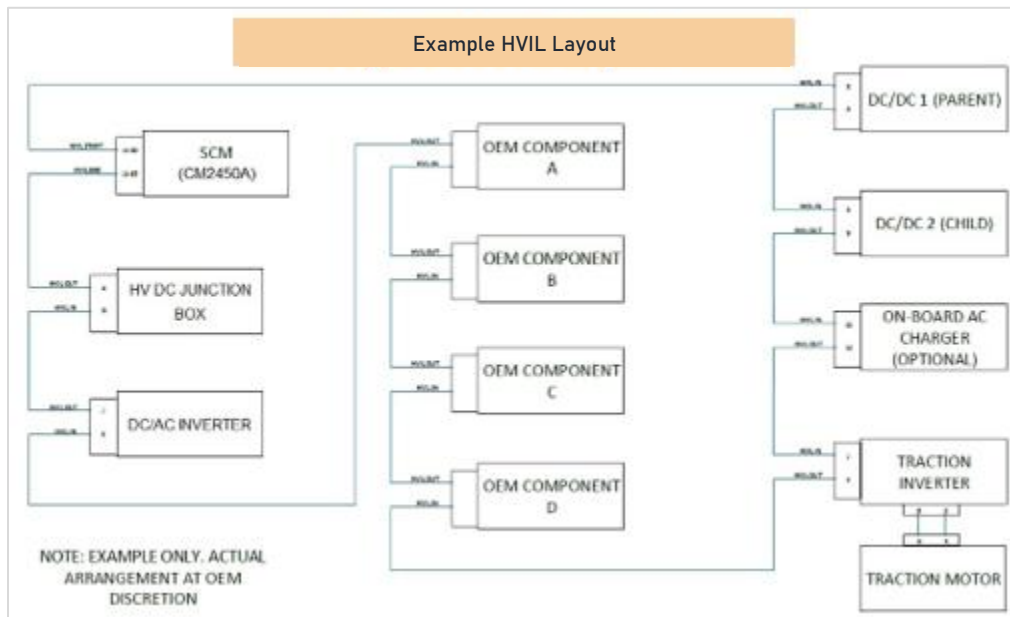


Figure 45 Typical HVIL layout diagram

This HVIL circuit will go through the cabling attached to that junction box. If you were to remove a cable from the junction box and forget to do your shutdown sequences, that HVIL would open, the low voltage controller would see an open circuit and try to disable high voltage by opening the contactors in the system to isolate high voltage to those parts. Thus, HVIL and the isolation loop, are the two first systems for safety.

If that happens again you will get an indicator on the instrument panel telling you have another exposure or HVIL issue, and this should be an indicator light that says “HVIL Fault” or something like that (see figure). For troubleshooting, you should check the HVIL low voltage circuit. Most people want to jump immediately to a high voltage problem, but it may just be a corroded wire or low voltage HVIL loop causing a high voltage problem (again low voltage controlling high voltage).



Figure 46 Example Cab or Driver display

As a rule of thumb, these safeties are there to protect you and will work *in theory*. They are built-in features of the system, **but they could still possibly fail**. Every OEM has a different way of going about HVIL and isolation. Make sure you look at that particular OEM's manuals to know exactly what to expect if you're getting a HVIL fault, so you can know what to do to repair it.

## ESS Thermal Management

Some OEMs use a liquid cooling system; other OEMs may use a fan-cooled system. As long as heat is removed and keeping the system in check, it is doing the right thing. Typically, this is a J1939 signal sent to the **Battery Thermal Management System**, or BTMS. Sometimes it may be referred to as Battery thermal management (BTM, but it depends on the OEM). The goal of the BTMS is to maintain the internal temperatures of the battery packs to prolong lifespan.

The target temperatures on the chart below display a range. Keep in mind that for us to make the batteries charge and discharge efficiently, it is necessary to maintain the batteries at a very specific temperature within a few degrees. Essentially, it is needed to control that temperature anytime the vehicle is awake and the contactors and the packs are closed. This could be stationary charging, or it could be regenerative braking. Make sure the cooling system is online to keep the batteries at the optimal temperature all of the time.

Whenever charging or discharging a battery it generates heat, so the HV battery systems are need to be heated, cooled, and subcooled.

| Target Temp = 20 C / 68 F |   |
|---------------------------|---|
| Winter                    | <b>Heating</b> request ON: 8 C / 46.4 F<br><b>Heating</b> request OFF: 10 C / 50 F  |
| Summer                    | <b>Cooling</b> request ON: 20 C / 68 F<br><b>Cooling</b> request OFF: 18 C / 64.4 F |

The Battery Thermal Management System is designed to maintain the internal temperatures of the battery packs to prolong their lifespan, and are going to consist of a few basic parts:

- A refrigeration loop
- A coolant heater
- A radiator
- A pump to move that fluid

Typically, the compressor for cooling and the heater for warming the batteries is a high voltage part, which is done on the high voltage side. Low voltage is used to activate the pump and turn the fans on so that we can cool or warm the coolant to get the batteries to the temperatures we need.

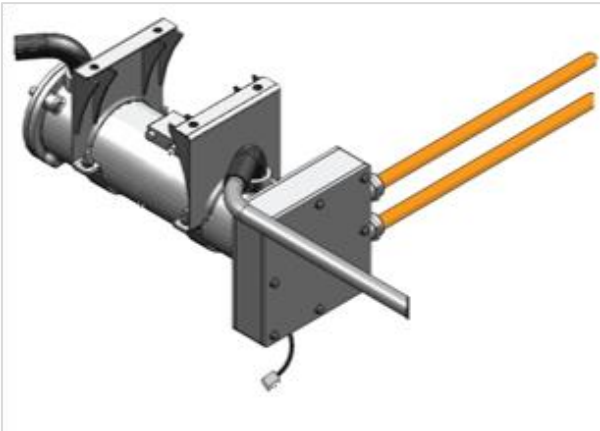


Figure 47 Battery Thermal Management System diagram

The schematic shown in Figure 48 is a simple circuit, but it will start in a reservoir. We will move the coolant out of the reservoir through the battery packs, and return it back to the reservoir through a surge tank and through a radiator or a fan system so we can heat or cool the batteries.

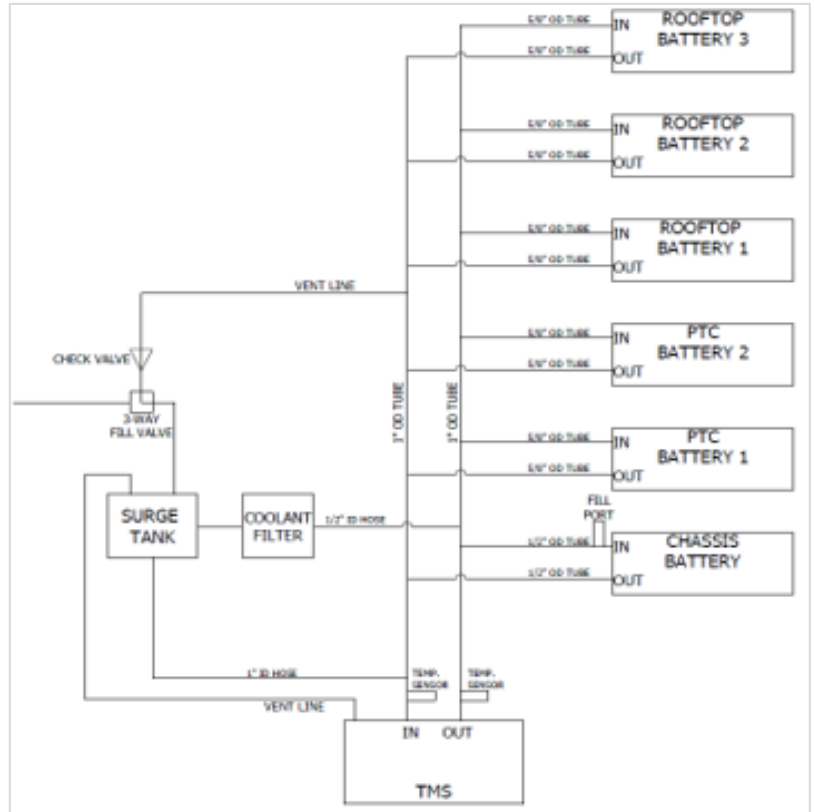


Figure 48 BTMS Line Diagram

What can affect our battery life is our distance or our range required, and how much we have to cool or heat those batteries, which affects our distance, our range, or both. This takes high voltage to do that, to either chill them or to heat them and that will take time away from distance and range on the battery packs.

## 1-6 PREVENTIVE MAINTENANCE

For a simple explanation, **preventive maintenance** [PM] is an act of performing a series of maintenance tasks within a regularly scheduled period to help prevent possible unexpected outcomes or failures of a vehicle later. This is a vital part of being a BEB technician, as regular PM will help catch and prevent any unintended failures.

The first table below is a compiled chart of many PM tasks (introduced after) that are performed on a BEB and provides the average PM interval schedule for each. Feel free to refer back to this chart for reference. **Remember that this is a guideline and it will be your agency protocol that determines when PM may be done.** The second chart lists various tasks associated with ICE buses that you would not need to perform PM on with a BEB.



**COURSE: FAMILIARIZATION TO BATTERY ELECTRIC BUS**

The maintenance intervals indicated in this section are based upon average vehicle use and typical operating conditions. Unusual vehicle operating conditions, such as geographic environmental conditions, will require service at more frequent intervals. It is the responsibility of the agency that purchases from an OEM to determine based upon experience with localized environmental conditions and local regulations to determine if more frequent intervals are required. The transit authority will be responsible for the performance of all scheduled maintenance to maintain the vehicle warranty

**Traditional Bus Preventive Maintenance Chart**

| PM Item                                 | Focus   | Initial | Weekly | Monthly | Quarterly | Semi-Annual | Annual |
|---|---------|---------|--------|---------|-----------|-------------|--------|
| Traction Motor                          | Lube    | x       |        | x       |           |             |        |
| Electric HVAC                           | Cycle   |         | x      |         |           |             |        |
| Battery Pack Voltage                    | Measure |         |        | x       |           |             |        |
| Battery Charging and Balance            | Measure |         |        | x       |           |             |        |
| Traction Motor                          | Inspect |         |        | x       |           |             |        |
| ESS Battery Chiller                     | Inspect |         |        |         | x         |             |        |
| High Voltage Cable Inspection           | Inspect |         |        |         | x         |             |        |
| LV (25 VDC) Electrical Wiring           | Inspect |         |        |         | x         |             |        |
| Rear Battery Strings Inspection         | Inspect |         |        |         | x         |             |        |
| Roof Top Battery Strings Inspection     | Inspect |         |        |         | x         |             |        |
| DC-DC Converter Inspection              | Inspect |         |        |         | x         |             |        |
| Roof Top Electronics Enclosure          | Inspect |         |        |         | x         |             |        |
| Traction Motor Inverter Inspection      | Inspect |         |        |         | x         |             |        |
| ESS Battery Cooler Condenser Inspection | Inspect |         |        |         | x         |             |        |
| HV Accessory Cable Inspection           | Inspect |         |        |         | x         |             |        |
| Power Steering                          | Inspect |         |        |         | x         |             |        |
| Air compressor                          | Inspect |         |        |         | x         |             |        |
| Charging Cable Receptacle               | Inspect |         |        |         | x         |             |        |
| HVAC System                             | Inspect |         |        |         |           | x           |        |
| Coolant Fluid                           | Inspect |         |        |         |           | x           |        |
| Low Voltage Distribution Box            | Inspect |         |        |         |           |             | x      |
| High Voltage Distribution Box           | Inspect |         |        |         |           |             | x      |
| Auxiliary Power Distribution Box        | Inspect |         |        |         |           |             | x      |
| Insulation Monitoring Device            | Inspect |         |        |         |           |             | x      |
| Battery Pack Inspection                 | Inspect |         |        |         |           |             | x      |
| Battery Thermal Management System       | Inspect |         |        |         | x         |             |        |

*Figure 49 Preventive Maintenance sample charts for traditional buses and BEBs*

## Battery Electric Bus Preventative Maintenance Chart

|    | Component    | Preventative Maintenance Item | Description                                  | Maintenance Interval (Miles unless noted by time) | Applicability to Battery-Electric Bus |
|----|--------------|-------------------------------|--|---|---------------------------------------|
| 1  | Alternator   | Bearings                      | Replacement                                  | 2-Years   | Not required                          |
| 2  | Engine       | Air Filter                    | Restriction Inspection                       | 3,000   | Not required                          |
| 3  | Engine       | Fluid and Filter              | Drain and Refill                             | 6,000   | Not required                          |
| 4  | Engine       | Primary Fuel Filter           | Replacement                                  | 6,000   | Not required                          |
| 5  | Engine       | Secondary Fuel Filter         | Replacement                                  | 15,000  | Not required                          |
| 6  | Engine       | Turbocharger                  | Inspection                                   | 30,000  | Not required                          |
| 7  | Engine       | Vibration Damper              | Inspection                                   | 30,000  | Not required                          |
| 8  | Engine       | Spark Plugs                   | Inspection / Replacement                     | 45,000  | Not required                          |
| 9  | Engine       | Ignition Coil                 | Inspection and Test                          | 45,000  | Not required                          |
| 10 | Engine       | Valves                        | Adjust                                       | 60,000  | Not required                          |
| 11 | Engine       | Oil-Water Separator           | Filter                                       | 2-Years   | Not required                          |
| 12 | Engine       | CNG Tank Vent Caps            | Inspection                                   | 6-Months  | Not required                          |
| 13 | Engine       | Oil-Water Separator           | Inspection                                   | 6-Months  | Not required                          |
| 14 | Engine       | Air Filter                    | Replacement                                  | As needed   | Not required                          |
| 15 | Engine       | Fluid                         | Check dipstick level                         | Daily   | Not required                          |
| 16 | Engine       | Crankcase Breather Tube       | Inspect                                      | Daily   | Not required                          |
| 17 | Engine       | CNG Fuel Filter               | Drain and Inspection                         | Daily   | Not required                          |
| 18 | Engine       | Muffler                       | Inspection                                   | Daily   | Not required                          |
| 19 | Engine       | Air In take Piping            | Inspection                                   | Daily   | Not required                          |
| 20 | Engine       | Gas Leak Detectors            | Inspection                                   | Monthly   | Not required                          |
| 21 | Engine       | CNG Fuel Tanks                | Inspection                                   | Yearly  | Not required                          |
| 22 | Transmission | Various conditions            | Inspect Breather, Mounting, bolts, oil leaks | 6,000   | Not required                          |
| 23 | Transmission | Fluid                         | Drain and Refill                             | 75,000  | Not required                          |
| 24 | Transmission | Filter                        | Change                                       | 75,000  | Not required                          |
| 25 | Transmission | Fluid                         | Check dipstick level                         | Daily   | Not required                          |

Figure 50 Preventive Maintenance sample charts for traditional buses and BEBs

## PM Schedule Intervals for BEBs

### Intervals

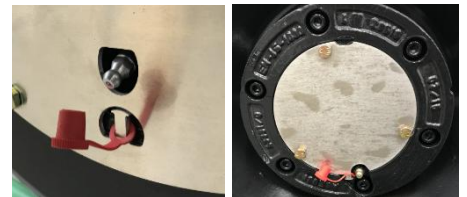
A lot of what goes on in BEB PM are inspections or related tasks, but general maintenance will be somewhat limited. These inspections will check for wires that are not shaking and no signs of heat damage or corrosion. For your standard PM intervals, you will find the following:

1. Initial PM (motor run-in, likely for all OEMs) — this is to ensure the initial capability of your vehicle is up to standard. Break-in PM will vary by manufacturer, but you should always expect to perform:



Figure 51 Examples of New Flyer Traction motor and grease fittings

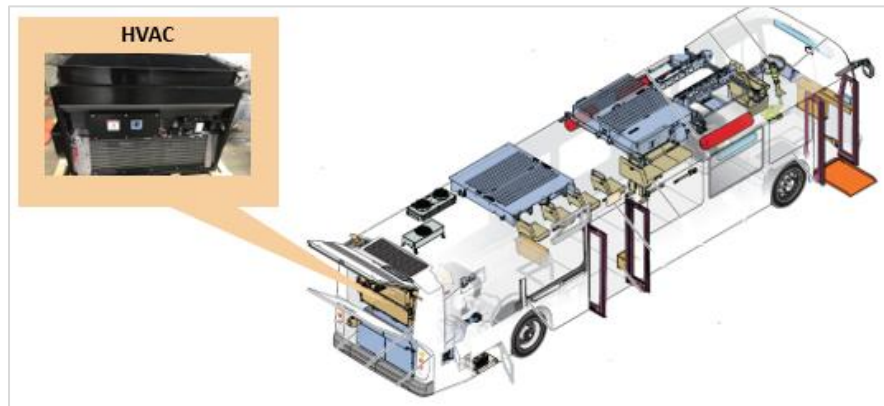
- a. Lubrication of all appropriate joints
- b. Inspection of all coolant lines
- c. Inspection of HV and LV terminals
- d. Retorquing any loose fasteners



- e. The motor also has coolant lines to ensure the motor does not overheat. Make sure lines are tight, not leaking, and fully functional.

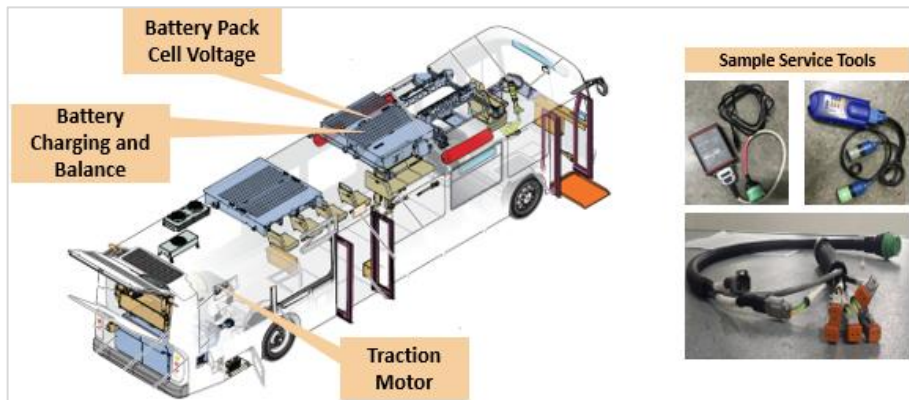
**COURSE: FAMILIARIZATION TO BATTERY ELECTRIC BUS**

- f. Grease traction motor fittings see (see figures right).
- 2. Weekly PM – At minimum these should be functional system checks for everything that is accessible without lifting the vehicle, including:
  - a. Inspection of diagnostics to check that there are no failure icons present on the dash
  - b. Inspection of the lights, body, wheels and tires (no different from other buses)
  - c. On a BEB, it is important that the HVAC is working and operational and exercising during normal operation. It can be located at the rear of the bus (see Figure 50). It has an electric scroll compressor and operates similarly to how the air conditioner would work on an ICE bus. Generally, it will be all electric.



*Figure 52 HVAC unit under weekly PM*

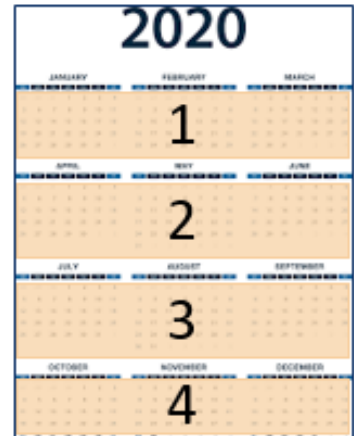
- 3. Monthly PM -
  - a. There may be general requirements to service the battery packs, from measuring the cell voltage to checking the battery charge and balance. Very routine tests and measurements can be done with diagnostic tools to verify the actual battery ESS is functioning at right levels.



*Figure 53 Battery pack and traction motor under monthly PM*

*COURSE: FAMILIARIZATION TO BATTERY ELECTRIC BUS*

- b. Inspection of the air filters on the pneumatic system
  - c. Lift the bus and perform routine state of health inspection of the underbody and suspension
  - d. Inspect ramp and door systems for proper operation and adjustment
4. Quarterly PM – These are less frequent, but several items related to the bus with more extensive efforts. Most of them will be inspections just to verify that any wiring is in good shape, and there are no signs of heat or chafing due to vibration, etc. Items to check include:



- a. Inspect the BTMS (battery thermal management system)
  - b. High voltage cables
  - c. Low voltage 12/24 VDC electrical wiring
  - d. ESS inspection (inspection of batteries)
  - e. DC-DC Converter inspection
  - f. Rooftop equipment
  - g. Power steering – will require more effort with maintenance; much like a mechanical steering system but hydraulic power is electrically created
  - h. Air compressor – will require more effort with maintenance
  - i. Charging cable receptacle – If it is depot charging generally there will be a charging cable per dispenser. One charger could have more than one dispenser (called sequential or cascade charging, this is when the charger can charge more than one bus off one charger in a sequential manner.) *The charger will be needed to perform this inspection and confirm the receptacle is working properly.*
5. Six-Month PM –
- a. Generally repeats much of the Quarterly inspections, as mentioned
  - b. Coolant may need to be assessed with a refractometer when applicable (important to ensure the electric motor that is generating a lot of heat is actually cooling properly.)
6. Annual PM –

- a. Low Voltage Distribution Box [Figure 53] – more in depth, varies from manufacturer to manufacturer
- b. High Voltage Distribution Box
- c. Auxiliary Power Distribution Box
- d. Insulation Monitoring Device
- e. Battery Pack (ESS or battery strings) inspection



Figure 54 Low Voltage Distribution Box

## Diagnostic Troubleshooting

### Diagnostic Software

As mentioned, many of the PM tasks will result in a need for inspection and maintenance. Since the BEB is an electric vehicle, we can't troubleshoot by normal mechanical means (for example if a cylinder is misfiring). This is so you can run diagnostics through the OEM software in order to accurately gauge and identify the areas needed for inspection. In order to troubleshoot BEBs you will at least the following software:

- Powertrain Diagnostic Software – This requires an OEM-specific program and software to run. Every OEM is going to have specific diagnostic software tools for the powertrain or ESS that goes with the bus that help determine a specific problem or conflict of that BEB in actual operation. This can be handled with a laptop.
- Battery Diagnostic Software – This requires an OEM-specific program and software to run.
- Typical Fault & Troubleshooting– Confirm compliant, diagnose fault and apply Corrective Action.
- Data Logging Software

### Diagnostic Tools

Tests are run through diagnostic software on high voltage components and areas to perform a quality check on the tested component or area to ensure safe operation during diagnostic checks, particularly looking at the effectiveness of the insulation. During testing, a specific amount and type of voltage can be produced and applied to check the quality of the tested component or area.

In order to correctly assess and measure diagnostics, you will also need a variety of tools to supplement the use of the OEM software that is used to control the software, record, and read data and measurements. Such tools will include the following:



**COURSE: FAMILIARIZATION TO BATTERY ELECTRIC BUS**



- Powertrain Dongle – an external plug/interface tool that allows external devices to connect to a laptop
- NEXIQ interface tool – works with the software. (for the Battery System Diagnostics specific to the bus)
- Laptop

Keep in mind that needed diagnostic tools can vary from manufacturer to manufacturer.

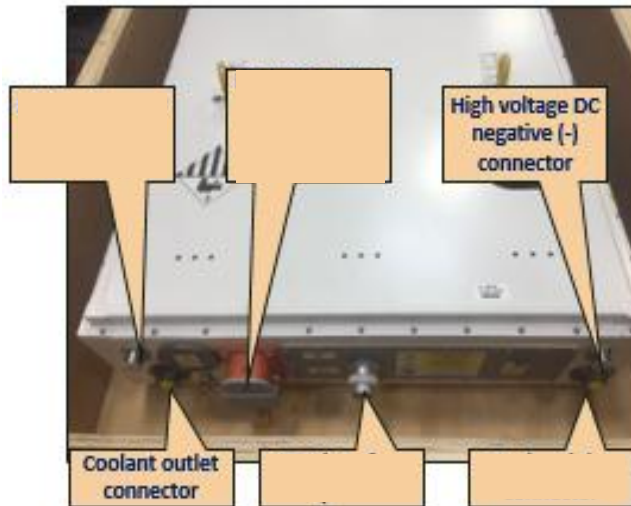
**Figure 55 Diagnostic powertrain dongle and NEXIQ interface tool**

---

**Learning Application 1F**

Without referring to your Guide, use the images and word bank to identify and label each of the locations of this ESS (battery pack).

Word Bank: High Voltage DC Positive (+), Coolant inlet connector, CAN interface port, Manual Service Disconnect location with Battery LOTO



## 1-7 SUMMARY

BEBs, while a type of electric vehicle, are not so different from traditional buses that are currently still in operation. However, there are certain aspects that remain vital to safe and efficient BEB operation. This module provided you an introductory look at the differences and similarities between the BEB and traditional bus types, a breakdown of the major components that are featured on a BEB, high voltage risks associated with BEB, and a look into preventive maintenance intervals and tasks that should be performed for a BEB.

Sources:

1. Proterra
  2. New Flyer
  3. Gillig
  4. Novabus
  5. ENC (formerly El Dorado)
-

# MODULE 2

## *Electrical Safety & Personal Protective Equipment*

### Outline & Learning Outcomes

- 2-1 Overview
- 2-2 Safety Considerations
  - 1) Recall the formula for calculating voltage
  - 2) Define high voltage risk and shop safety conditions
  - 3) Recall the SAE standards pertaining to BEBs
  - 4) Identify primary built-in safety features and recall their function
- 2-3 Personal Protective Equipment [PPE]
  - 1) Identify typical PPE involved with BEB maintenance under NFPA70E Category ratings
  - 2) Recall the primary functions of each PPE introduced
  - 3) Recall the procedures for testing and inspecting HV gloves
- 2-4 Safety & Testing Equipment
  - 1) Explain the purpose of the appropriate safety and testing equipment
  - 2) Identify when to use the appropriate safety and testing equipment
- 2-5 De-Energizing or LOTO [Lock-Out/Tag-Out] of BEB Electrical Systems
  - 1) Recall the proper de-energization procedure for an 800-volt Proterra bus
  - 2) Demonstrate the ability to perform a LOTO on an 800-volt Proterra bus (only applicable to in-person training with qualified personnel)
  - 3) Recall the proper de-energization procedure for a New Flyer bus
  - 4) Demonstrate the ability to perform a LOTO on a New Flyer bus (only applicable to in-person training with qualified personnel)
- 2-6 Summary

This module gives an overview of electrical fundamentals and safety precautions relevant to BEB technicians, an introduction to PPE and the NFPA70E standard ratings, common testing and safety equipment used, and it ends with a video demonstration of the de-energization process for two bus manufacturer models. Following the completion of this module, the participant should be able to complete the outcomes with an accuracy of 80% or greater.



## 2-1 OVERVIEW

As bus techs you are already experts on diesel engines, but you may now be asked to work on hybrid buses. In the near future, you'll be asked to work on fully electric buses. It's perfectly normal to have concerns. DC voltages on BEBs run as high as 800VDC, and there are multiple sources of energy. The buses may look the same, but this is a very different setup from our standard 24VDC starter batteries and diesel engine. This module will introduce you to the safety aspects, equipment, testing, and de-energization procedures that help reinforce your safety while performing inspection, maintenance, and troubleshooting with a BEB.

As a reminder, this course session is not intended to be a replacement for a full-course on HV safety, but it should act as an introduction to worker safety for working on and around battery electric buses. It is our hope that you will have a comfortable level of reassurance that both worker and passenger safety is built into the designs of all battery electric buses, so you can and will be able to work safely.



*Figure 56 SAE Standards for BEB*

In addition to the familiar Society of Automotive Engineers (SAE) charging standards introduced, there are many other established industry standards. Standards vary by governing body. Some examples include:

- **OSHA** – Occupational Safety and Health Association, Standards 1910-302-308, deal with electrical systems, not limited to vehicles, and related standards for safety.
- **NFPA** – National Fire Protection Association, Standards 70B and 70E are two examples of best practices when dealing with electrical systems. They also provide first responder training. A subset body of OSHA.
- **IEEE** – Institute of Electric and Electronics Engineers, is the knowledge base for all electrical and continues to develop electric vehicle standards like IEEE 2030.11, which deals with transfer of power between chargers and vehicles.
- **FMVSS** – Federal Motor Vehicle Safety Standards, Standard 305, which was established to cover the design of early Hybrid and BEB buses.
- **NHSTA** – National Highway Traffic Safety Administration, a federal agency that works with state and local governments devoted to enforcing vehicle performance standards that reduce vehicle deaths, incidents and economic losses

Some of these standards are for your protection and apply to the design of the vehicles. These four agencies are big on standards in our world. OSHA of course has a number of standards but specifically 1910.302-308 deals with electrical systems in vehicles (not limited to vehicles but it does cover our vehicles).

NFPA has examples of best practices of dealing with electrical systems. They also provide first responder training. Something NFPA covers is if you have ever taken a bus in and out of a venue to do a show or presentation, they will tell you how much charge or fuel that particular bus can have. IEEE (the Institute of Electrical and Electronics Engineers) have long set the regulations and standards in the electrical world. They also cover under 2030.11 electric vehicles. FMVSS standards (produced by the National Highway Transportation Safety Administration, or NHTSA) in standard 305, which was originally established for hybrid buses, also covers BEBs.

## 2-2 FUNDAMENTALS & SAFETY CONSIDERATIONS

As a refresher or basic introduction, let's familiarize you with several basic but important laws that govern electrical principles that you should always keep in mind when working with electronics and electric vehicles.

### Electrical Fundamentals & Laws

“**Voltage**” is the pressure from an electrical circuit's power source that pushes the charged electrons (or the current) through a conducting loop, enabling them to do work. Voltage can be produced by many sources, including chemical sources (batteries and chemical reactions inside the battery creating potential difference) and mechanical sources (alternators/generators, spinning a magnet inside a coil of wire creating potential difference). The most common automotive voltages are 12V and 24V outputs.

“**Current**” is the rate at which electrons flow past a point in a complete electrical circuit. Something crucial to note is that **current is flow**. Any differences in potential can create a source of current. Electrical flow needs a path, so if there is no set path then there will be no current (no current, no flow).

“**Resistance**” is the opposition to current flow in an electrical circuit. Everything has a resistance factor, and this can be divided into two categories: **insulators** or **conductors**. Insulators are materials with an intrinsically high resistance value, meaning current has a more difficult time flowing through that path. Conductors are the opposite to insulators, meaning they have an intrinsically low resistance value that more easily allows current to flow through.

**Voltage, current and resistance all interact in a circuit.** Voltage usually will be set from the electrical source in a circuit, often from the 12V or 24V output of many devices. Current flow through resistors will produce a voltage drop across each one, and the total resistance in the circuit dictates the maximum amount of current that will flow through the circuit.

## Ohm's Law

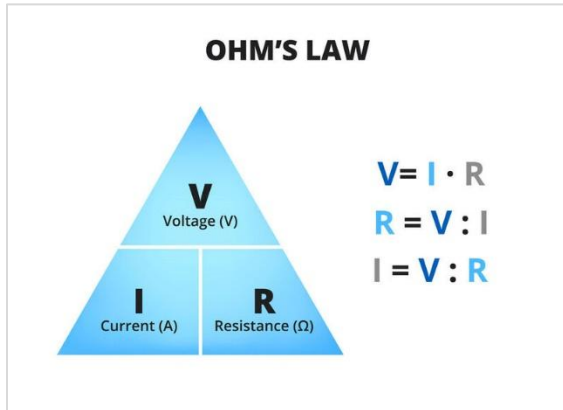


Figure 57 Ohm's Law Relationship Triangle (courtesy of Power and Beyond.com)

As mentioned, the three units of voltage, current and resistance all interact within a circuit. This relationship is represented as one of the most fundamental aspects to be aware of for electricity — the formula known as **Ohm's Law**. Ohm's Law is a formula that can help you make many calculations, particularly the amount of current (voltage) running through any conductor from one point to another.

Ohm's Law is a formula represented by symbols as  $V = I \times R$  and is considered the most important formula to comprehend (may be represented using other variables or symbols). Using Ohm's Law will

allow you to calculate and find the amount of voltage dependent on the amount of current flowing and the level of resistance found in that circuit.

Ohm's Law is a great tool to calculate missing variables in a circuit. Anytime you have questions about how to find out how much voltage should be in a circuit, if you have the current resistance values, you can always go to  $V = I \times R$  and calculate it since resistance and current are inverse.

## Watt's Law

Based on the chart above, let's now look at the lower left-hand corner, where the letter "P" is the symbol for power and the very top equation there is V (voltage) times I (current). **Power** in our field is the measure of a quantity of work that circuits can yield, or what amount of power an electrical component can consume in a given time period and is measured in joules per second (J/sec) or watts (W). This is represented by another formula known as **Watt's Law**, which means power is calculated by voltage times current, or  $P = V \times I$ .

Let's say your bus carries 300,000 watts of energy, and your battery voltage is 600 volts. That means you have the potential to have 500 amps at any given time coming from those batteries. This is more than enough to do damage to you, so you need to be aware of that right from the start.

Some additional electrical fundamentals include but are not limited to:

- **Faraday's Law of Induction**
  - Law of electromagnetism to predict how a magnetic field might interact with a circuit and produce electromagnetic force (aka electromagnetic induction)

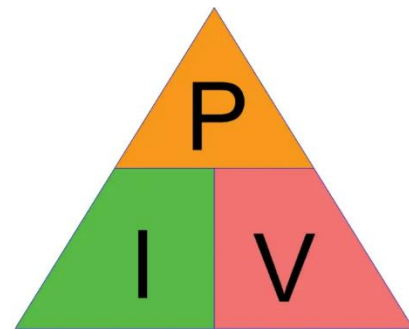


Figure 58 Watt's Law Relationship Triangle (courtesy of Electrical Volt.com)

- **Lenz’s Law**
  - Applies to the process of power conversion and transformers on the bus and adheres to the principle of the conservation of energy applied to electromagnetic induction (i.e. energy is not destroyed but changed or transformed).
  - An inductive current, in the context of electromagnetism, will flow in a direction that opposes any initial change of a magnetic field that resulted in that flow.
- **Kirchhoff’s First Law: The Current Law (KCL)**
  - Refers to the fact that the total current that enters a point or junction is equivalent to the amount of current leaving that point or junction. This adheres to the conservation of charge, represented by the formula  $I_{\text{enter}} + I_{\text{exit}} = 0$ .
- **Kirchhoff’s Second Law: The Voltage Law (KVL)**
  - Deals with the conservation of energy principle — that energy cannot be created or destroyed, simply changed or transformed. Voltage around a loop is equal to the sum of every voltage drop for the whole loop of any closed circuit and totals out to zero. Represented by the formula  $V_a + V_b + V_c + V_d = 0$ .

### Electrical Schematic Basics

It is important that you are skilled in interpreting electrical schematics, which are drawings or visual representations of the electrical connection points between components or systems. These documents will provide an outline of functionality for an electrical circuit and serve as the basis to begin to troubleshoot electrical components and systems. We won’t go into the specifics of all that needs to be reviewed on reading schematics. The figure below displays common symbols you will come across and need to know what they represent on a schematic:

Knowing how to read schematics is very important for BEB maintenance, because if you lose any of the high voltage subsystems you will need to understand where in the circuit there could be a break. Whether it be a device itself, the component that’s failed, or whether it be in the electrical connections (it could be a bad cable or a cable that’s damaged — i.e. there could be a short somewhere). You should use electrical schematics to identify where in that circuit any of this could exist.

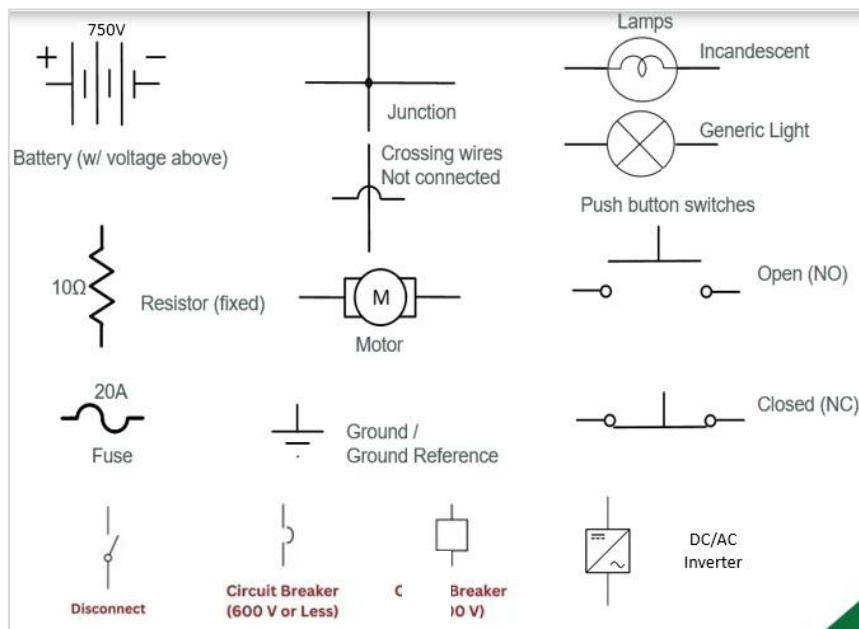
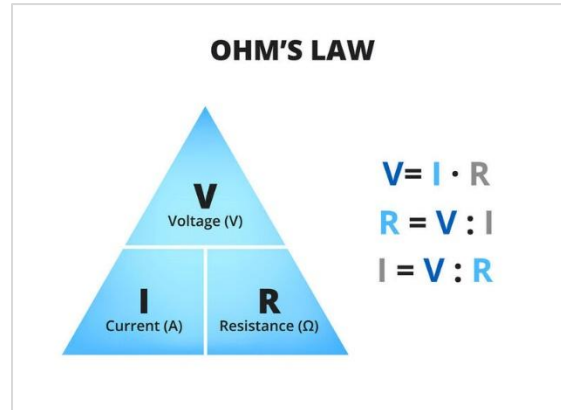


Figure 59 Common electrical schematic icons

## Learning Application 2A

Review the following image, and answer the questions below:



1. What variables that are used to calculate voltage?
  2. Given a current of 2 Amps (I) and a Resistance (Ω) of 5, what would be the calculated voltage?
  3. Given a Voltage (V) of 18 and a Current (I) of 6 amps, what would be the calculated resistance (Ω)?
- 

## Safety Considerations, Hazards, and Risks

BEBs are not unlike other buses, but they have their own new and unique safety risks and concerns. Just the bus outside of the electric drive and the larger battery packs warrant their own safety features. There are new challenges coming out, but they will become the new norm and are easily managed and mitigated by the built-in safety features.

### Definition of High Voltage

The definition of high voltage as it relates to a battery electric bus is any voltage over **50 volts**, which will actually be dangerous to you. Once again, current is the biggest danger in doing the damage.

Common BEB energy storage systems today can total between 100-800 (kilowatt-hours) the voltage is the potential that does the work, but the current that flows through the circuits is what we actually need to be mindful of. Rating for kWh is a measurement of energy, equivalent to one hour of electricity produced at a rate of 1 kilowatt-hour. You can refer back to the sample battery specs from Module 1 for a specific example.

All high-voltage components or areas that house high voltage components will be identified via a hazardous voltage label that usually consists of a yellow triangle, a black thunderbolt, and warning text. The figure right displays representations for a number of labels and decals. These are not all you will see on our buses, but you'll notice some are marked in red for danger, others cautionary in yellow. Pay attention to these labels. They vary amongst the OEMs, so the components and the labeling on each bus may be different. As mentioned earlier, **they will be clearly identified and marked for you to see.**



Figure 60 Example HV warning labels

Always pay attention to the labeling. Make sure that you're familiar with the OEM's manual, make sure you have a chance to look at it before you work on a bus, and make sure that you're familiar with your OEM's battery electric bus specific high voltage system. This is important because there can be a possibility that the warning label/sticker(s) may be damaged or removed from the area.

### Effects of High Voltage on the Human Body

When talking about milliamps (one thousandth of an amp) and with one milliamp we can feel a slight tingle. You may have felt it before, like from 9-volt batteries. With 5 milliamps you'll feel a little bit of a shock. With 6 to 30 milliamps – you'll start feeling a little pain and muscle shock. The figure can put into perspective what current can do to the human body, and this figure has the expectation that there are 50V or more in the circuit. The reason being is that without a sufficient voltage present, what would potentially be a lethal amount of current cannot flow, as there is not enough push from the driving force of voltage.

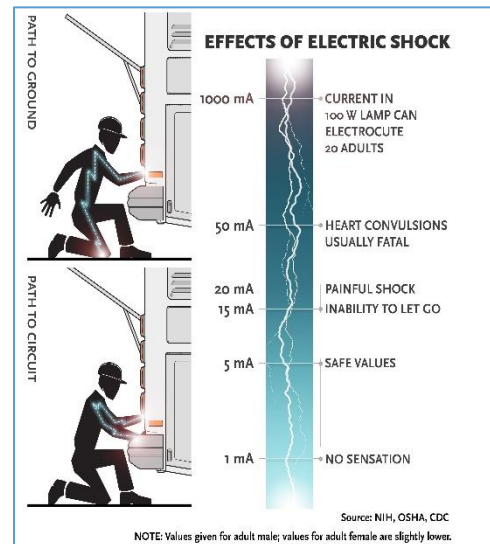


Figure 61 Effects of HV on the body

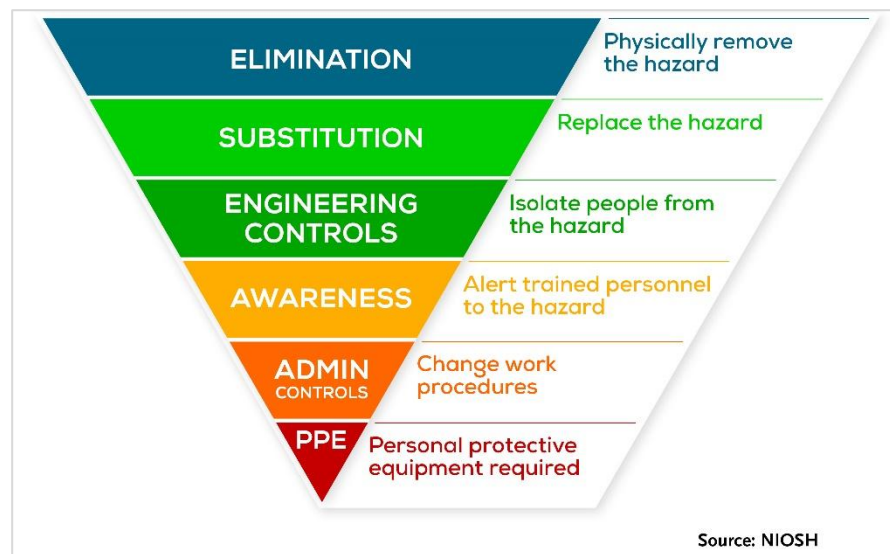
This starts the range where your muscles contract and allow you to pull away from the harmful current. When current reaches between 50 to 150 milliamps you can experience respiratory arrest, severe muscle contractions, and the possibility of death. With 1000 to 4300 milliamps (that's 1 amp to 4.3 amps), you'll feel ventricle fibrillation (that's the heart pumping out of rhythm), your muscles will definitely contract, and death is likely. Once you reach 10 amps or more, you will have a severe burn, and death is probable.

### Safety Considerations

- A **hazard** is something that can cause harm.
  - Hazard Identification – this means spotting and identifying hazards: electrical, chemical, etc. These will be identified by placards or labels and referenced in service and repair manuals as well as operation manuals. They will be identified in your operation and servicing of these vehicles

## COURSE: BATTERY ELECTRIC BUS FAMILIARIZATION

- A **risk** “is the chance, high or low, that any hazard will actually cause somebody harm.” A risk can also be described as exposure to danger, harm or loss. We want to avoid this and eliminate risks.
  - Risk assessments are required (per NFPA 70E – Article 320) and a necessary workplace safety practice – especially when working on HV. These assessments identify the hazards associated with the type of tasks to be performed and assess the risks associated with these tasks that lead to safe work practices and the use/requirement for PPE (gloves, glasses, fall protection, etc.).
- Risk assessments and workplace safety should be a crucial process and part of each property’s training and safety goals and objectives. Risk assessments are necessary, and they’ll help to prevent risks, hazards, and potential associated injuries. They also help improve tasks and provide the necessary task steps and associated tooling and PPE.



*Figure 62 Inverted pyramid of safety responsibility*

### Safety DOs and DON'Ts

- Know the system you are working on. You **MUST** be trained and qualified to work on HV systems. If you are uncertain if this applies to you, **ASK**.
  - See how OSHA describes qualified personnel - [1910.332 - Training | Occupational Safety and Health Administration \(osha.gov\)](https://www.osha-slc.gov/1910.332-Training).
- Familiarize yourself with OSHA and NIOSH standards (Canada). Check out the following sites:
  - <https://www.osha.gov/shpguidelines/hazard-identification.html>
  - <https://www.cdc.gov/niosh/topics/hierarchy/default.html>

## COURSE: BATTERY ELECTRIC BUS FAMILIARIZATION

- **Always verify HV is off – “Test before you touch”.** NEVER assume the system is safely de-energized.
  - DO NOT touch any exposed metal inside a high voltage component, enclosure, cabinet, or conduit.
  - DO NOT touch any fluid observed leaking from high voltage areas.
  - DO NOT pierce, pry open, dismantle, or force open any area labeled with the “high voltage” warnings.
  - DO NOT insert any tools or body parts into any holes, cracks, crevices, or other openings in or near any areas labeled with “high voltage.”
- **NEVER work on an HV system by yourself. Have a qualified second person as an observer and a safety backup.**
  - This relates to performing zero-volt testing, working in a battery pack, or working on live HV systems (a rare occurrence)
- Always apply your own lock [perform LOTO] when performing work on a vehicle.
- Think before you work: what PPE will you need, what are the risks, who’s responsible for ID risks, techs, safety committee, OEM, (fall protection) agency specific, etc.
  - In most cases both members should wear the same set of PPE
- Concerns – explosion, gas, shock wave, injury (high impact from blast, heat, etc.)
- What to do – assessments, plans, engineering controls, PPE

### High Voltage Safety Hazards and Risks

Let’s review some key hazard and risk principles to understand. What are some of the risks and safety hazards from high voltage equipment associated with HV electric vehicles and BEBs? Some of the typical events can include:

#### 1. Increased risk of electrical shock hazards and shocks – HV, HV Cabling & HV systems & components

- HV shocks can lead to death, as any voltage above 50V could be lethal.
- Chance to experience injury, burns or even fall
- Wear PPE. The second step is to eliminate risk by performing Lock out/ Tag Out procedures.
- Identify and brush up on First Aid and CPR procedures in cases of emergency



## 2. Arc Flashing

An arc flash is a sudden release of energy or undesired electric discharge that generates intense light and heat that radiates at supersonic speed (between conductors or from a conductor to a ground). This can occur in both high and low voltage environments! However, arc flashing should be a rare occurrence when safely working in and around properly maintained electrical equipment if you follow safety precautions.

The resulting explosion can cause fires and serious harm to equipment and people. The temperature of an arc flash may exceed 35,000 degrees Fahrenheit, which is capable of vaporizing metal and sending a blast of plasma and molten metal in all directions with extreme force, along with some of the following results:

- **Burns:** When an electric arc occurs, it generates immediate extreme temperature and increased risk of severe burns
- **Metal projections:** Metal explodes when an electric arc occurs and super-heated shrapnel can be projected in every direction
- **Fall from Height:** In many installations, the HV batteries are mounted on the vehicle roof. Human instinct is to *recoil* from an arc flash, which could cause a fall from a height of greater than ten feet [ $>10'$ ], but even falling from four feet can be bad.
- **Concussive blasts** – an explosion that results in a blow to the head caused by the resulting force from an arc flash
- **Fall Protection** – As an explosion could result in a fall if you are working above ground level, take precautions around working from height, which could mean fall-protection harnesses lanyards, ladders and work platforms.
- Generally, the higher the voltage, the higher the risk, but damage is caused both by the explosion of the arc flash and by the heat radiating from the blast.

## 3. Thermal Runaway Event

A **thermal runaway** event can be explained as a condition that typically occurs due to increased heat and temperature conditions within the battery packs, that is created when the heat generated within a battery exceeds the amount of heat that is dissipated to its surroundings. This can result from abuse (damage, overcharging, etc.), contributing environmental conditions (such as salt-water intrusion), etc.

Once started, the condition (increased temperature which causes increased current) will continue and create a domino effect — as heat will remove the resistance, and the overall heat affecting the circuitry, system or current, which leads to a continuous cycle - thus the term Thermal (heat) Runaway. (**Mitsubishi**)

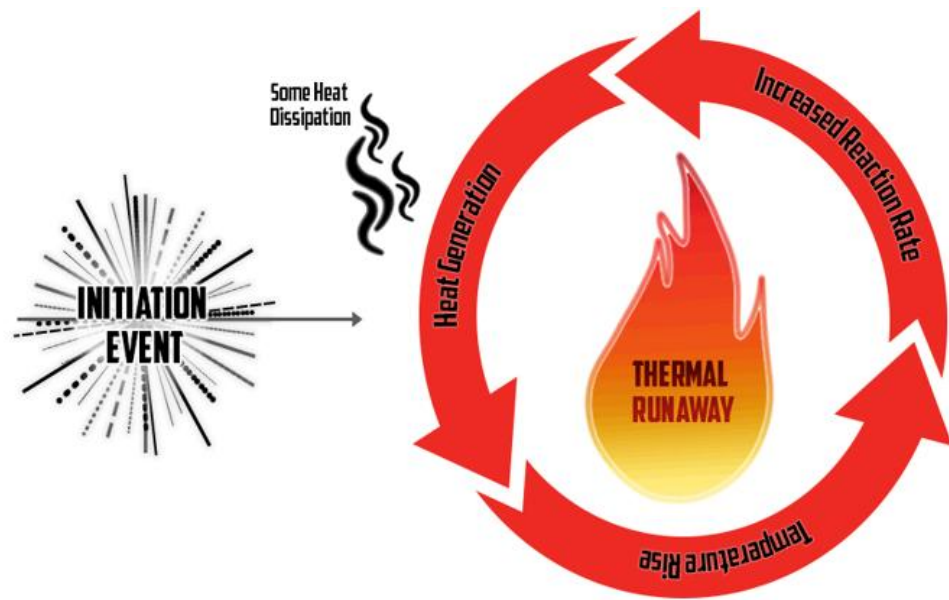


Figure 63 Diagram of a thermal runaway event – courtesy of Mitsubishi Electric

The biggest concerns are potential fires and/or battery explosions. This effect is very dangerous but also very rare and can be managed. Here are some tips and strategies to remember in the event of thermal runaway:

- First and foremost are design and engineering controls or safety features. Flame retardants, ventilation (for thermal release), and monitoring for the beginning signs of thermal runaway.
- Pay attention to warning labels and understand their placement and use! They are there for a reason – do not dismiss. You should always heed safety warnings!
- Monitor isolate and evacuate/contact emergency personnel (if uncontrollable).
- Front end & back end of bus – locate and identify front end/rear run controls
- Familiarize yourself with the bus
  - If an event does start, the best measures are to get away and let safety personnel handle it.
  - Monitoring, temperature control, and venting are critical as are designs to prevent them.
  - Determine or recalling the battery chemistry makeup: It's important to note that water **CAN** be used on a lithium ion battery when trying to cool a fire/thermal runaway. Consult the relevant safety data sheets (SDS)

## COURSE: BATTERY ELECTRIC BUS FAMILIARIZATION

- When you see these (manual and on components/vehicle) – you need to follow PPE and safety instructions.

### HV & Arc Flash Safety

We have introduced some safety considerations for HV and Arc Flash safety in Module 1. For additional review, here are some more general rule-of-thumb safety tips and items that can be utilized regarding HV safety:

- Any stored energy (even after de-energization) that measures greater than 10 joules should be treated as if it were a hazard.
- In order for electric current to flow, there is a need for a potential difference. When this potential difference is isolated, it is possible (with the proper PPE and safety tools) to perform maintenance around energized or live systems.
- **ALWAYS** wear PPE. Better safe than sorry.
  - **Make sure that your gear is rated for the anticipated use or maintenance you expect to encounter. Check the color-coding system if your agency has one in place**
- Regularly inspect systems, subsystems, HV equipment and PPE for wear, damage, punctures, tears or deterioration.
- Risk Assessments and the **4 P's Model** (Predict-Prevent-Protect-Publish) - An effective model to arc flash management crucial in understanding and preventing potential injuries due to this phenomenon.
  - *Predict* – This means to calculate and validate, pertaining to any potential hazards or risks to determine the potential severity of the arc flash and its effects.
  - *Prevent* – Helps to mitigate the chances of arc flash using principles of prevention. This can be similar to the hierarchy of controls when planning, designing, and eliminating risks.
  - *Protect* – The ability to reduce risks and hazards with protection and/or the proper PPE, especially if risks cannot be eliminated or removed.
  - *Publish* – Refers to the collection of information and materials for risk assessment for use in training and providing safety warnings and procedures where risks cannot be eliminated or removed, such as holding safety committees.
- Know the system you are working on. You **MUST** be trained and qualified to work on HV systems. If you are uncertain this applies to you or if you have any questions, **ASK**.
- Performing any work is always safer with HV shut off. Never assume a system is safely de-energized. **Always verify that the HV is off:** “Test before you touch.”

## COURSE: BATTERY ELECTRIC BUS FAMILIARIZATION

- **Never work on HV systems by yourself.** You need a qualified second person as a safety and an observer.
- **Always apply your own lock** when performing work on the vehicle, as your safety is ultimately in your hands.

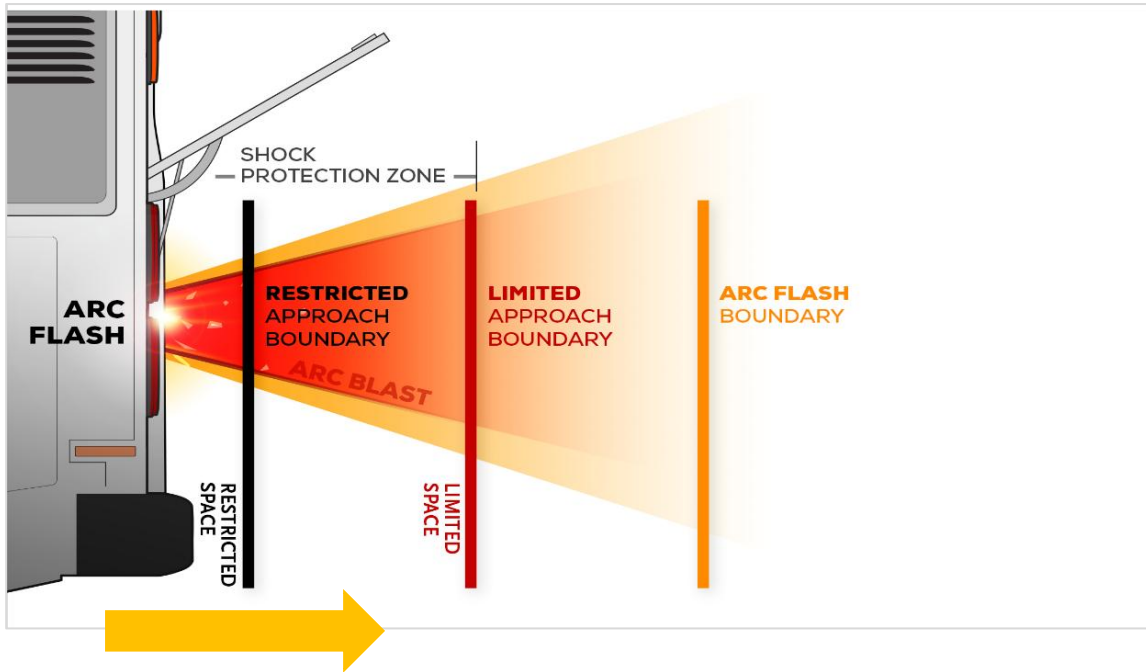
For some general rule-of-thumb safety regarding arc flash:

- Arc flash can occur at a small scale, such as during installation or removal of equipment, or disconnecting of switches.
- Arc flash can occur in small spaces such as a crawl space or enclosures, and can occur in large rooms such as a machine room or agency's shop
- Any of the following can result in an arc flash:
  - Dust, dropped tools, condensation and moisture, corrosion, faulty installation, accidental touch of conductors, and equipment failure
- The severity of an arc flash can depend on three primary factors:
  - Proximity of the individual to the event, size of the resulting explosion, time the individual was exposed to the blast
- One major management system for arc flashes is the compliance of an agency with OSHA and NFPA regulations, primarily the NFPA 70E standard. This standard addresses electrical safety and contains the necessary requirements to mitigate potential shock and arc flash hazards.
  - Through NPFA 70E, only qualified and trained personnel are allowed to perform work on or near energized electrical systems.

### Limits of Approach

The specific boundaries set by NFPA 70E for employee protection when working on or near any energized equipment. This includes three distinct boundaries:

- **Arc Flash Protection Boundary** – Also known as the outer boundary, this is the farthest boundary from any energized equipment or area, typically 4 feet out for barrier setup. Should an arc flash occur, an employee at this boundary would get treatable first-degree burns. This boundary should not be crossed unless you have the appropriate PPE on.
- **Limited Approach** – This boundary is the distance where any barriers should be set up to offer protection and safe distance for employees.
- **Restricted Approach** – This is the boundary distance of an increased shock hazard and risk(s). Only qualified personnel should be allowed within this limit with the required PPE on.



|    |               | RESTRICTED          | LIMITED            | ARC FLASH              |
|----|---------------|---------------------|--------------------|------------------------|
| AC | 151 V – 750 V | 12"<br>(0.3 METERS) | 3' 6"<br>(1 METER) | EQUIPMENT<br>DEPENDENT |
|    | 50 – 150 V    | AVOID CONTACT       | 3' 6"<br>(1 METER) |                        |
|    | <50 V         | NOT SPECIFIED       |                    |                        |
| DC | 301 V – 1 kV  | 12"<br>(0.3 METERS) | 3' 6"<br>(1 METER) | EQUIPMENT<br>DEPENDENT |
|    | 50 – 300 V    | AVOID CONTACT       | 3' 6"<br>(1 METER) |                        |
|    | <50 V         | NOT SPECIFIED       |                    |                        |

Source: NFPA 70E Tables 130.4(E)(a) and 130.4(E)(b)

Figure 64 NFPA 70E Limits of Approach and approach values for AC and DC - courtesy of Immersed Technologies

The NFPA 70E Table displays the range of voltages and distances that would be the appropriate distance within the Restricted, Limited and Arc Flash boundaries for both AC and DC voltages. The standard is 3' feet 6 inches away, but many agencies will use a 4-foot distance boundary as an additional precaution.

### **Arc Flash Warning Labels**

Knowing the sections and information available on arc flash warning signs is important. See the image below and the breakdown of its sections:

- Danger or warning header
- Working distance – distance between person and arc source
- Incident energy – amount of thermal energy
- Arc Flash boundary – distance a person to stand in the boundary that they would receive second-degree burns if not protected
- Shock Hazard when cover is removed – the equipment's voltage level
- Limited approach boundary
- Restricted approach boundary
- Glove class – Proper rating of required rubber insulated gloves

- Arc Flash PPE category rating



Figure 65 Example Arc Flash Warning Label

### Additional Safety Hazards and Concerns:

- Keep in mind that batteries always have “energy present.” The concern here is “live” energy and potential for fire and explosion (TR). There is a lot of potential energy in battery electrical buses, and it is present everywhere in the HV systems of the bus. Bus manufacturers are now building 600 kWh buses. This is six times the energy of the current longest-range Tesla.
- Heavy component handling (lifting)with battery packs – With regular maintenance, batteries should not need to be replaced often, however replacing them does present a hazard.
  - Note: Battery packs may be located on rooftops, so there is the potential for injuries due to falls. Therefore, fall protection is required.
- Silent Operation – A new aspect of BEBs is that they are and operate very quiet. That causes concerns both in service and in the garage, so check everywhere! Garage, in-service, etc. You must be aware of both as an operator and in the operation and vicinity of BEBs. Many buses are now equipped with automated announcements and alarms for this reason (mainly for in-service).
  - Effects on personal medical devices – Electrical systems could have an effect on pacemakers.
  - Increased battery packs mean an increased potential for hazards – electrical, chemical, etc.

---

### Learning Application 2B

Either with a partner or in a group, discuss the following: “How would you identify key safety considerations and risks for each of the following hazards?”

You may write in this section or on a separate page.

1. Electric shock



2. Arc Flash



3. Thermal runaway event

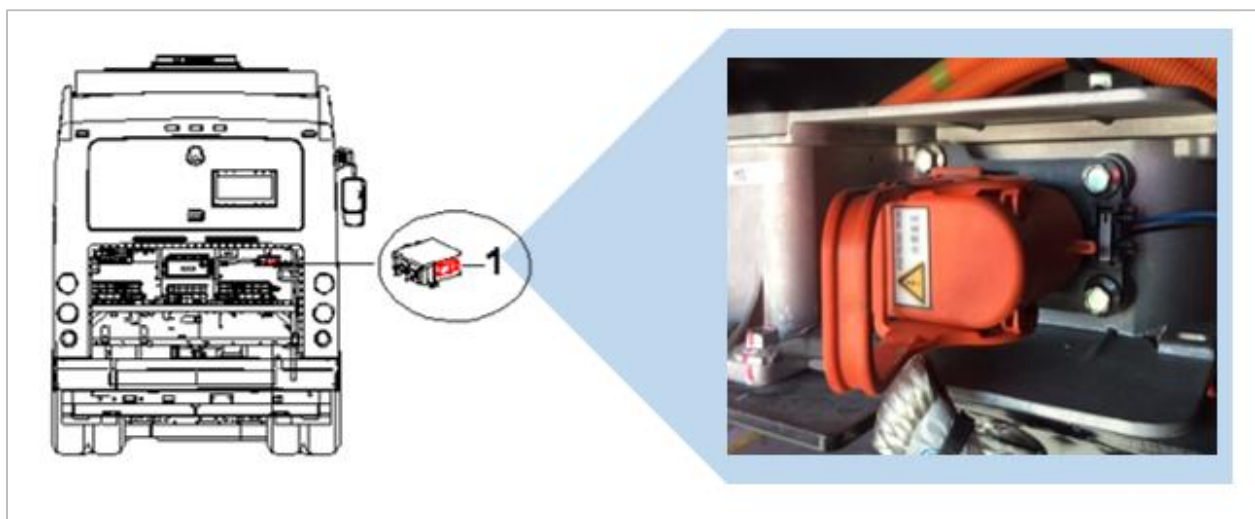
## Integral BEB Safety Features

BEBs, while not entirely different from traditional buses, still have several new design features that makes working or performing maintenance on them more dangerous. As such, bus manufacturers must keep safety in mind at all times and have designed these buses with built-in features that can prevent the possibility of HV accidents or unsafe conditions. What are some of the built-in safety features that OEMs will incorporate and include in the design of their buses?

### Manual Service Disconnect [MSD]

The **manual service disconnect** (commonly called an MSD) is a safety device that acts as a two-level plug that can be removed from the bus and quickly isolates the HV battery pack from the HV circuit. This acts as a shunt or fuse on the positive side of the HV power. Removing it causes an open circuit, preventing current flow. Before removing, ensure that the low voltage (or house batteries) is (are) off or disconnected. Designs vary by manufacturer, and the removal of each requires specific procedures that can be found in the OEMs maintenance and repair manual.

The figure below is another example of a safety MSD to remove/isolate HV with the battery manual service disconnect. Each OEM has their own built in and located possibly in different areas.



*Figure 66 Manual Service Disconnect diagram with location*

*Although it is extremely and highly unlikely to come into contact with any high voltage doing a PM, it is recommended to remove the Service Plug to prevent any possible current flow.*

**First disconnect this plug without switching off the Battery Disconnect Switch, EXCEPT for emergencies.** There is no need for special PPE in relation to HV during a routine PM inspection.

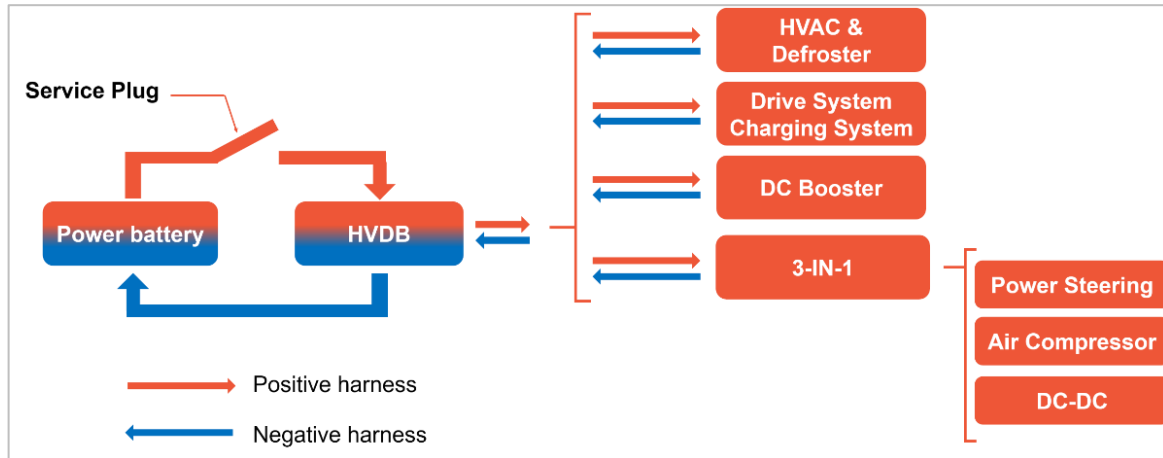


Figure 67 Illustration of basic MSD process

The figure above shows an example safety feature, an overview of a high voltage battery disconnect and an isolation of power, which is from a BYD model bus. You will have the battery power, your distribution block, and right in between (the distribution block allows the power to flow to and from various components and systems on the bus). If you break that loop or take the battery disconnect away, you remove any concerns.

### High Voltage Interlock Loop [HVIL]

The High Voltage Interlock Loop (HVIL) is a single low voltage circuit which passes in series through high voltage connection point on the vehicle. The HVIL helps prevent unintended high voltage exposure to technicians. It is a circuit that is installed to detect if high voltage enclosures are opened, when connectors are removed and/or components are damaged.

The HVIL system starts and ends inside a low voltage controller. The responsible controller outputs a low voltage signal onto HVIL circuit and looks for the signal to be returned to the controller after going through the loop.

The figure demonstrates another built in safety feature you may have already been exposed to if you have been working on hybrid electric bus. A High Voltage Interlock Loop (HVIL) system and *Control Strategy* is provided for an alternative fuel vehicle including an electric, a hybrid electric, or a fuel cell vehicle. The

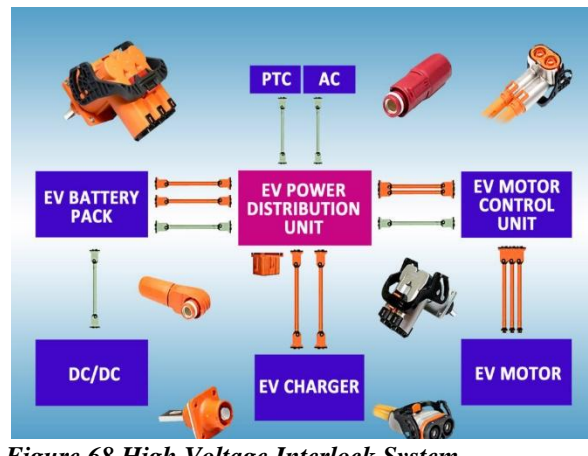


Figure 68 High Voltage Interlock System relationships example

following is an OEM specific example from a Proterra ZX5 bus, and demonstrates that the HVIL runs through all the HV components. Another example includes New Flyer buses that monitor so when opened an indicator/icon for HVIL exposure will go off of the dash.

**The HVIL circuit runs through the HV junction box and every HV device to monitor connections any break will disable the HV system.**

- Troubleshooting this system will require that the vehicle be in a low-voltage-on mode of operation.
- **Ensure that the vehicle has all LOTO procedures verified before you start troubleshooting any HV systems**
- **The HVIL is a system designed to prevent unexpected exposure to High Voltage. It is not intended as a way to isolate the High Voltage system. High Voltage isolation should always be accomplished via the LOTO process.**

If a high voltage connection to a high voltage component is removed, the HVIL loop will be broken. The controller will measure an open circuit, and the high voltage contactors in the system will be opened, isolating all high voltage to the ESS battery packs. As an impact for integral safety systems, an HVIL loop serves to ensure that the high voltage contactors within the ESS battery packs will be opened and high voltage will be contained within the ESS whenever someone tries to access high voltage systems while energized.

Generally, the HVIL system's associated logic includes an HVIL circuit which is provided to allow the vehicle to operate in either a high voltage (HV) or power mode powered by a power source or a HVIL interrupt mode based on an operational state of the HVIL system.

The HVIL system loop is always active whenever the bus low voltage system is on. Removing power to the low voltage system will automatically ensure that the contactors within the ESS battery packs are open and there is no high voltage present outside the ESS battery packs. HV battery packs will have a separate HVIL system.

All OEMs handle HVIL slightly differently. Please refer to the electrical schematic manual supplied with the bus for correct operation and wiring of the HVIL circuit. Figure 68 demonstrates a simple HVIL diagram.

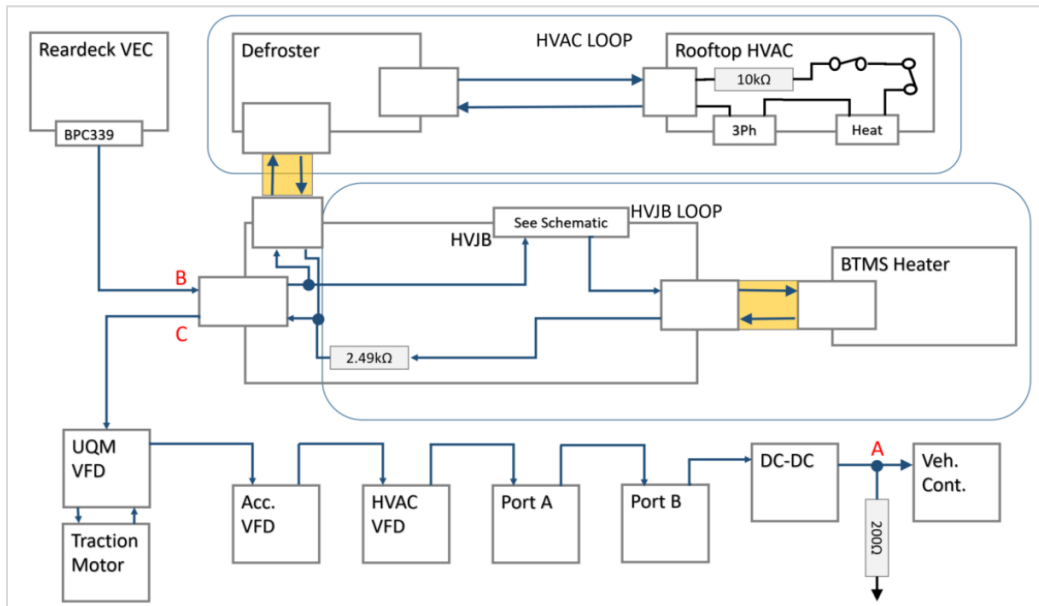


Figure 69 Simple HVIL diagram of defroster

#### Additional notes on HVIL safety:

A foundation of safely working on high-voltage powertrains and accessories is the High-Voltage Interlock Loop. Each and every access panel and connectors in a high-voltage system will have either a physical switch or wire-loop that are all interconnected on a single low-voltage (12/24v) loop. When you physically open the access and place yourself within an air-gap of high-voltage components, this switch will open, and that action will shut down the high-voltage system by opening all contactors at energy sources.

HVIL loops work off either 12V or 24VDC and will see any system voltage below 10.8 or 22.6 V as an open and will shut down the HV. This is crucial to keeping 12V batteries in good working order and not to let them drain. Much like a diesel bus, dead 12V batteries means a BEB can't be "started" or moved.

With BEBs, there are dozens and dozens of HVIL switch and connectors, which means dozens and dozens of devices that can go wrong and left inadvertently open. This will shut down the bus and make it immobile. It's crucial to ALWAYS fix any HVIL issues and never to bypass the switches, even for diagnostic purposes in the shop. This system is designed and intended to keep both passengers and technicians safe, and bypassing it would not be a smart move.

## Passive Propagation Resistance



Passive Propagation Resistance [PPR] is a safety feature within the batteries modules/ESS. The feature of PPR allows individual cell units within the battery to be encased in a specialized foam material, which acts as a strong isolator material in-between the cells.

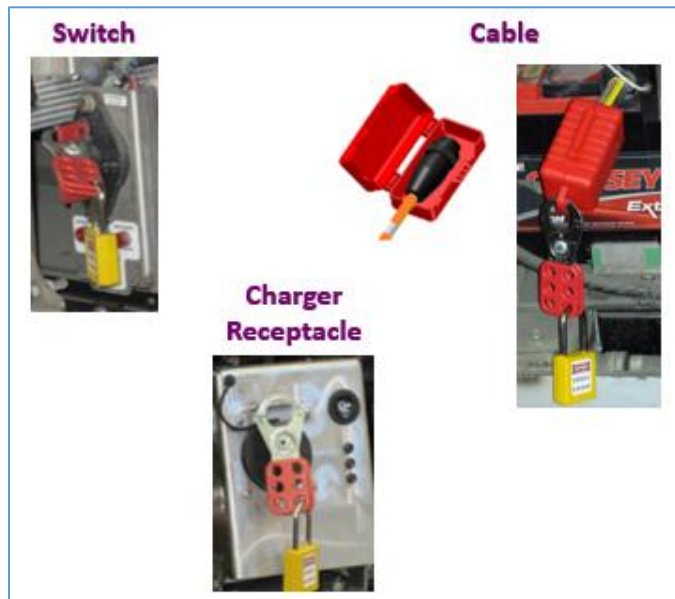
This is useful for safety because if a cell slips into a continual heating cycle (causing a thermal runaway event, which can spread to surrounding battery cells), the material reduces the probability of a thermal runaway event by preventing the chain of battery heating.

*Figure 70 Passive Propagation Resistance inside a battery cell*

## Shop Safety Practices

**Lock out/Tag Out** or **LOTO** (may also be known as the electrical disconnect verification procedure) is a series of steps done in conjunction with de-energizing the bus, which makes the bus safe to be worked on, **with no HV present**. It also makes the bus safe for anyone else who will work on the bus afterward by notifying anyone who comes in afterward that there is someone else currently performing maintenance there. This is done with a lock and ticket (tag) system that provides a record of a technician's specific information and duties on that area.

Vehicle specific procedures will apply, but generally we lock out switches, cables and various other locations where inputs (even low-voltage) could energize a HV circuit.



*Figure 71 Sample LOTO Equipment*

The above figure showcases a depot charger plug receptacle and a 24V battery disconnect switch. That charger receptacle is an entry point for high voltage, so we need to lock it out as well. With battery cables coming to and from high voltage sources of energy (like the battery), we would lock those cable ends with a red box over them and then lock that box closed.

We must always follow the procedure specified by the OEM or vendor in a systematic and orderly fashion. Specific examples of LOTO will be introduced later in this module.

***\*Only qualified personnel should be performing LOTO at their agency.***

### **Why do we lockout and tag out?**

This is so we can isolate every source or potential source of energy and be 100% sure that no one can reenergize a circuit. LOTO is a two-man verification procedure that the system is 100% safe to work on. **Otherwise, you must assume that high voltage is present.** The technician performing the job should be watched by a second person. The second person is focused only on watching and is ready to react if a safety instance were to occur. The second person should also be wearing the proper PPE and gloves, while having an electrical rescue hook in hand if required.

It is important to keep in mind, BEBs will have multiple sources of energy. Locking out or de-energizing the vehicle must always be done according to the manufacturer's process, and OEMs will ask that these procedures are followed very closely.

Tagout devices are prominent warning devices that a technician fastens to energy-isolating devices (locks) to warn employees not to reenergize the machine while he or she services or maintains it.

- This could be a warning label or a picture of the technician who locked out the circuit.
- LOTO is a smart and safety-focused thing to do and is mandated as part of OSHA.
  - OSHA requires an employer to establish an energy control procedure, removing the energy supply from machines, and for putting appropriate LOTO devices on the energy-isolating device to prevent unexpected re-energization (wording directly from the standard).

While effective in practice, **you should never solely rely on any computer or system to keep you safe as a verification system.** It is vital to physically disconnect each potential energy source. To verify there is no voltage present afterwards, you must lock it out so no person can reconnect that source of energy while you are working on or near that high voltage equipment.

### **First Aid & CPR**

As shop technicians who may experience an electrical hazard event, such as someone coming in contact with an electric shock, it is essential that standard practices like safety training in both cardiopulmonary resuscitation (commonly known as CPR) and applying first aid techniques. Knowing these practices can help you respond quickly and appropriately administer immediate medical care until the proper medical service personnel arrive. This helps to mitigate the potential lethality if someone becomes involved in an electrical hazard event. Not every agency will offer this training, so it may be offered through a third-party vendor or safety training organization instead.

Some suggested steps if you were to encounter an electrical hazard victim:

- Locate and turn off the source of the hazard. If it is not accessible or feasible to do so, remove the source plug or power supply to the area.

## COURSE: BATTERY ELECTRIC BUS FAMILIARIZATION

- If needed, you can attempt to remove the victim from the hazards with your insulated equipment. Be sure to maintain ground and approach distance as to avoid closing the circuit.
- Call 911 to notify rescue personnel to arrive on the scene as soon as possible.
  - If you have the training, you may administer CPR and First aid/an AED device.
  - Notify any other personnel in the immediate vicinity.

*As a good recommendation, it is advised that you seek out or attend first aid training that specializes in electrical hazards.*

### **Releasing Victim from HV**

If this scenario were to happen and you have to determine what to do when someone is incapacitated and unable to remove themselves from a HV condition, what do you do as the safety observer? Ideally you and the observer should be in the same PPE and have safety/rescue equipment on-hand.

Then the first thing to attempt is to remove the victim from the source or circuit. This is because the longer they remain in contact with the energy source, the greater the injury will be. Additionally, because someone has come into contact with an energy source, it means the equipment has failed and isolation may not be possible, so there is a testing process that needs to be handled on the equipment functions. It is critical that you **DO NOT attempt to move or pull a person away from the electrical source without protection**. There may be residual electricity that can travel to you, especially if the area has HV around.

Once someone has been removed from the source, the next step is to notify any emergency or medical personnel as soon as possible. In addition to this, check to see if the person has a pulse and is still breathing. It may be necessary to perform CPR until emergency medical staff arrive. However, **DO NOT** attempt CPR if you are not trained to do so. If you **have not** been trained, 911 can instruct you on what to do over the phone until paramedics arrive.

Another consideration is to turn off the electrical source by locating the electrical isolation source. If you cannot do this quickly, the next best thing would be to find or use a non-conductive item (like a rescue/shepherd's hook) or even a wooden pole, and attempt to move the person off or away from the electrical source.

Again, it is not recommended that you move or pull a person away from the electrical source without protection in case you become energized too. However, in the event that you do not have the appropriate PPE on, it may be necessary for you to perform what is known as a "last stance" effort if you are not able to perform a non-conductive release. This means attempting to remove someone from an electrical source using your own body. As it sounds, this is highly dangerous and can lead to being shocked or incapacitated yourself, and as such, this is not endorsed as a method for rescuing someone from HV unless absolutely necessary.

## Learning Application 2C

Either with a partner or by yourself, discuss and determine primary functions of the integral BEB safety features introduced in this section. You may write in this section or on a separate page.

1. Manual Service Disconnect [MSD]



2. High Voltage Interlock Loop [HVIL]

3. Passive Propagation Resistance

---

## Shutting Down HV Quickly

In this situation, you will need to know what steps to take in order to ensure that any HV is immediately shut down to prevent further damage or risk of casualties. Identifying any HV locations and components, such as the traction motor (as mentioned in Module 1) is critical to working safely and managing risk.

“Knifing” the bus (low-voltage battery disconnect switch). The design of how these loops work will vary between OEMs, but the design premise is always the same. It’s a low-voltage loop which is always monitored by every ECU in the bus. Open any portion of the loop and the high-voltage contactors are all opened.

Another option may be to remove a manual service disconnect [MSD] if that can be done. The MSD will typically be located at the back of the bus (maintenance on New Flyer battery would be located up on the rooftop) and can be removed from its slot by pressing the locking tab down while at the same time pulling the release handle down at approximately a 45-degree angle. However, location, design and removal process will vary by OEM.



## Emergency Response

What happens when we need to respond to an accident or incident in-service? We need to ensure everyone is aware of the risks & hazards (concerns) associated with BEBs. Typically, we think about first-responders. A **first responder** is typically emergency medical crew, fire department, and police department personnel. Before addressing first responders, we will go over many of the roles and responsibilities of any personnel involved in the protocol that should be in place at your agency. These roles, responsibilities and even terms may vary between agencies.

1. The vehicle operators play the largest initial role in responding to in-service accidents and incidents. They operate the vehicle and are responsible for knowing how the vehicle operates, including understanding the telltale lights and alarms. They act as the first line of defense by reacting to issues and concerns to ensure the safety of passengers and relay information back to dispatch (getting passengers off the bus if necessary).
  - a. Listening to what's happening, assessing and responding as necessary (for assessment & response)
  - b. Communicating to the street supervisor, maintenance, and possible emergency personnel
  - c. They will stay on top of the situation until the situation is under control.
2. Emergency responders on the front end (before anything gets to an escalated level) should have been working with your department/authority to identify the specific risks and hazards associated with BEBs (where HV is going, shut off features, house batteries, etc.). Most properties do this to maintain the awareness so when first responders are called upon they will follow protocols to ensure public and passenger safety and protect the vehicle to the best of their ability.



*Figure 72 Vehicle Operator*

- a. Police for traffic controls, EMT's for passenger needs (injuries, etc.), Fire and Emergency Response Personnel for fires and safety concerns (smoke, etc.).
3. The maintenance road crew typically have responsibility to make any repairs that need to be done and also tow the bus and/or assist. In most instances, these personnel will be considered second responders. They will likely be consulted where needed for mechanical/technical experience and expertise.



*Figure 74 Emergency Responder*



*Figure 73 Roadside Maintenance crew*

## COURSE: BATTERY ELECTRIC BUS FAMILIARIZATION

4. Tow Truck drivers (also known as “wreckers”) can be included as a sort of 2<sup>nd</sup> response crew (In emergency responses only)
  - a. They will need to know the window of the vehicle’s re-ignition potential. This is typically between a 24 and 72-hour isolation period
5. The road supervisor is your next line of defense, and considered second responders. For example, if the operator is out in service and comes across an electrical issue with their vehicle, they should follow protocols and contact dispatch to let them know what’s happening. They are instrumental in assessing, reporting and following-up on the accident/incident.
  - a. Dispatch immediately assesses the situation, take information down, and contact the road supervisors, who will then respond to the scene.
  - b. Typically, most road supervisors are the ones to act, and work with maintenance crew and first responders if things escalate. Responders should follow agency standard operating procedures and guidelines for any incidents



*Figure 75 Road Supervisor*

Every agency will have a process in place for safely securing the vehicle. These are (not all inclusive):

- As soon as possible, safely pull over/off the road.
- Secure the vehicle (Park-Parking Brake On-Four Ways On-Vehicle Off if necessary).
- Assess the situation, and contact dispatch and relay issue/concern (canned message).
- If a safety issue occurs (fire, smoke, etc.), get passengers off of the vehicle and a safe distance away from the vehicle.

These buses are designed with many safety features to warn of issues and to prevent issues. Coupled with the engineering features and emergency service protocols, there should be no major issues. Attention, procedures (protocols), actions, and communications should allow all situations to be managed. The last important detail is follow-up. A review and learning from all incidents/accidents go a long way in ensuring risks and hazards are minimal and safe operations.

**Prior to any of this, the training departments of the company/property will have put together Hazardous Communications and Protocols to deal with any potential issues related to these buses and will have worked closely with local municipalities to go over response protocols and requirements. The local police and fire departments will be made aware of the HV systems and the controls in place on the bus as well as the make-up of these systems and what is needed in the worst-case scenarios (TR, Fire, etc.). Much of these protocols and communications are already in place and should only require updating to the new equipment and standards.**

## 2-3 PERSONAL PROTECTIVE EQUIPMENT [PPE]

**If the PPE demonstration is not available, use Section 2-3 as the next part of the course.**

At this point, your instructor will hand out **Hands-On Learning Exercise 2D**. This will be an active learning demonstration of PPE, the process of applying and wear any PPE and conducting PPE inspections. Please make sure that you are able to see the instructor and the PPE demonstration.

To perform those three steps, certain PPE and tools are required. Analysis of the exact PPE required for different jobs on a vehicle are vendor-specific, and are dependent on the arc flash potential risk analysis (which should be described in NFPA 70E). The category ratings below identify the NFPA70E primary category ratings:

1. PPE Category 0: For Shock hazard only
2. PPE Category 1: Minimum Arc Rating = 4 calories/cm<sup>2</sup>
3. PPE Category 2: Minimum Arc Rating = 8 calories/cm<sup>2</sup>
4. PPE Category 3: Minimum Arc Rating = 25 calories/cm<sup>2</sup>
5. PPE Category 4: Minimum Arc Rating = 40 calories/cm<sup>2</sup>

Category 0 - Shock Hazard PPE includes the following:

- HV rubber gloves and leather overlays
- Electrical Hazards [EH] rated safety shoes
- Safety Glasses

These category rankings are the provided requirement to obtain the appropriate PPE at the amount of energy (measured in calories/cm<sup>2</sup>) on material or layers that lead to a 50% reduction in cases of 2<sup>nd</sup> degree burns. Check out the latest NFPA70E (2021 edition) for more information.

**An important mention is that most BEB tasks and maintenance will not require use of any PPE above Category 2 rating.** Use the table in Learning Application 2D for future reference.

Each of the following will be arc-rated PPE that should be required or used as needed when performing work on a BEB, including those listed under shock hazard PPE. As needed, PPE clothing can include: arc-rated jacket, parka or rainwear, hard hat liner, but are likely not required in most situations. Along with the required clothing, one must also have the following: hard hat eye protection (safety goggles or glasses), hearing protection or earplugs (inserts); heavy duty leather footwear.



Figure 76 Examples of typical PPE worn during BEB maintenance

### Class 0, High Voltage and Leather Gloves

| ASTM Labeling Chart<br>Natural Rubber Electrical Insulating Gloves |                          |                        |  |
|--|--------------------------|------------------------|--|
| Class Color  | Proof Test Voltage AC/DC | Max. Use Voltage AC/DC | Insulating Rubber Glove Label                        |
| 00<br>Beige  | 2,500 / 10,000           | 500 / 750              | 10<br>ASTM D1170<br>CLASS 00<br>MAX USE VOLT 500V AC |
| 0<br>Red   | 5,000 / 20,000           | 1,000 / 1,500          | 10<br>ASTM D1170<br>CLASS 0<br>MAX USE VOLT 1000V AC |
| 1<br>White   | 10,000 / 40,000          | 7,500 / 11,250         | 10<br>ASTM D1170<br>CLASS 1<br>MAX USE VOLT 1000V AC |
| 2<br>Yellow  | 20,000 / 50,000          | 17,000 / 25,500        | 10<br>ASTM D1170<br>CLASS 2<br>MAX USE VOLT 1000V AC |
| 3<br>Green   | 30,000 / 60,000          | 26,500 / 39,750        | 10<br>ASTM D1170<br>CLASS 3<br>MAX USE VOLT 1000V AC |
| 4<br>Orange  | 40,000 / 70,000          | 36,000 / 54,000        | 10<br>ASTM D1170<br>CLASS 4<br>MAX USE VOLT 1000V AC |

Class 0 gloves with a **RED** label required.

Figure 77 Insulated glove ratings chart

Rubber gloves and leather gloves (worn over top of the rubber gloves are not shown here) are foundational safety gear for keeping yourself safe when working near high voltage equipment or in the act of locking out and confirming that lock out. When choosing gloves, keep in mind:

## COURSE: BATTERY ELECTRIC BUS FAMILIARIZATION

- The de-energization of the bus could take a couple of hours (especially the first time or couple times you do it). You will be wearing gloves the entire time, so you want to have gloves that fit well and maintain dexterity when using our hand tools.
  - The figure above shows black rubber gloves, and they have a tag with a red label on them (ASTM standard). This pair is likely size 10, so you want to make sure you have gloves that fit you well.
  - It is not recommended that you use shop-level gloves if you're going to be working on BEB. **Use Class 0 for maintenance.**
  - Technicians should have their own gloves that they take care of, with the chosen pair of gloves based on the maximum voltage they will protect us from. Though this may vary depending on the size of the agency.
  - The color of the rubber can vary, but the label color is specified by the ASTM (American Society for Testing and Materials) standard. Gloves can be multiple colors (orange, black, etc.), but they will always have the tag that allows us to work up to 1000 volts (AC) and 1500 volts (DC) with that pair.
  - As a best practice, leathers should always be worn over the rubber gloves to protect from nicks, scratches and cuts, as well as providing an additional layer of protection.
  - As mentioned, these are rubber gloves and will be hot and not always comfortable, so some technicians choose to wear light cotton gloves underneath the rubber gloves. This is not necessary from a safety perspective but can improve the comfort.

## Electrical Hazard Rated Safety Shoes

Another important piece of PPE you need to have on you is a pair of electrical hazard [EH] rated safety shoes. You want to find EH rated shoes compared to electrostatic dissipative [ESD] rated which are geared towards reducing static charges.

These are worn to avoid forming a path to ground. While there can be variations in what your agency deems as appropriate footwear, common safety shoes will be anti-slip, and rubber insulated to protect from shock and slipping hazards. These are important PPE to have on as these are almost universally recommended by each manufacturer when working on BEBs.

*NFPA70E does not require EH footwear for shock protection, though it is required when you might encounter arc flash scenarios at or above a risk of 4 cal/cm<sup>2</sup>.*



**Figure 78 Electrical hazard rated shoes – courtesy of Carhartt**

## HV Glove Inspection & Testing

Agencies need to start thinking about processes for maintaining and testing gloves, with similar thinking around torque wrenches regarding labelling, dates, calcs, etc. Prior to use, make sure the PPE you are testing is being done on the right voltage rating. As technicians you have different methods for glove inspections:

1) The “blow-and-fold” (manual) technique can be performed prior to any use of the gloves, and seeks to check for or detect:



Figure 79 Manual glove inflation inspection

- Users can roll gloves in their hands or inflate them manually to better expose imperfections and air leaks.
- Holes, perforations, tears, cuts, cracks, burn marks, air bubbles, encrusted or bonded material

### 2) Use of a specialized glove inflator

- The usual frequency for periodic inspections is between 30 and 90 days. This can be used when performing glove inspection but may not be available in all shops.
- You can use a glove inflator [see figure right]. It has a distinguishable red top and black base. The glove is placed over top of it and inflates the glove. Then we can carefully inspect and hold the glove up to our face, making sure it stays inflated, even bringing it close to our chin or cheek to feel if any air is escaping. However, **do not** stretch gloves beyond 1.5x standard size.
  - Allows for closer inspection of webbing between fingers and gauntlet



Figure 80 Sample glove inflator

### 3) Dielectric tests (send away to a lab).

- To make sure gloves maintain their insulating properties, dielectric testing by a recognized, qualified laboratory is required.



Figure 81 Approved tested stamp for gloves

- The date of dielectric testing must be logged or printed on each glove. This date will be stamped on the gloves when you first purchase them. After being tested a new tag on top (or date) will be added to show they have been retested
- Rubber gloves should be replaced every 6 months (from date of service), or annually if they have been on the shelf.

For the technician in the shop, you will inspect your gloves visually and roll test them before every job involving HV, i.e. lock-out/tag out or

decommissioning the vehicle. It will be the supervisor's (or similar person's) job who looks after shop tools, like torque wrenches, to maintain the gloves.

## 2-4 SAFETY & TESTING EQUIPMENT

While you may be protected when you don PPE in order to perform inspection, maintenance and/or troubleshooting, having those layers are only half of the formula. What is also needed is the proper inspection and testing equipment that will help you determine, verify, or assist with safety while working on a BEB.



Figure 82 Example digital multimeter

### Meters & Digital Multimeter

Behind gloves, the next most important tool or equipment you need is a meter, and more specifically a Digital Multi-Meter. A meter is any device that can be used to take measurements, and there are several that measure one specific unit:

- Ammeter – measures current
- Voltmeter – measures voltage only
- Ohmmeter – measures resistance; gives an actual resistance unit between two points
  - Most meters will offer two options for resistance: continuity and ohmmeter (continuity in our case means that the points are electrically connected and a circuit exists)
  - **ALWAYS measure resistance with the circuit powered off.**
- Megohmmeters – measures very large resistances
- Milli-ohmmeter – measures very small resistances, often used to verify HV equipment repairs

The most common meter nowadays is a **digital multimeter**, as this meter combines several measuring devices into one device. This is an instrument that is used on electronic devices, components, and areas that reads and measures values for items like voltage, current, and resistance. These meters use attachments called **leads** (or **test leads**) that are devices that directly connect to a circuit to read and display the specified measurement(s).



Figure 83 Digital multimeter in use

For working with a BEB, these meters **must be CAT III rated**, for both the meter and special test leads. This means they are rated for measuring voltages up to 1000 volts DC. It's important to check that both the DMM and the leads are rated CAT III. Be sure you monitor that leads stay with their respective meters when being used in the shop, though the standard would be using Fluke Category IV rated meters. Just make sure you wear the same rated gear.

### Verify Test Verify

What do we use a digital multimeter for? It is used to check the isolation after the de-energization process, which is given to you by your vendor, the bus manufacturer. We need to verify that there is no voltage at an energy source after de-energization. This is done in a three-step process known as “**verify-test-verify**,” also known as “**live-dead-live**.”

- 1) Start by testing a known good voltage source (ideally new or near new), and confirm the multimeter is working properly.
- 2) You will then test the high voltage component on the bus (wearing proper PPE). If you're doing the LOTO procedure, confirm there is no voltage present between the positive and negative terminals and then each positive and negative terminal to a chassis ground.
- 3) Then test that same voltage source previously tested again to verify that your multimeter was working properly.

Following this three-step process means any job or task will take longer. However, someone's life – particularly yours – is reliant on taking your time and working safely.

### Taking measurements with a multimeter

Because a meter/multimeter is an indispensable tool as a BEB technician, it is vital that you know how to use it accurately and understand how to take and read measurements with one. After covering the idea of **verify-test-verify** (or “**live-dead-live**”) the next step is to practice using a meter in order to take and read voltage measurements.



Figure 84 Multimeter test verify test process



At this point, if a meter is available your instructor will move to **Hands-On Exercise 2E**. This will be an active learning demonstration of how to use a meter with the “Verify, Test, Verify” process.

## Current Probe [1000v Category III/600 Cat IV]

A current probe is a meter that has clamps on the end which open and close, allowing for the “jaws” to clamp around an electrical component or conductor. This process allows for direct measurement of current without the need for physical contact, or disconnecting and needing insertion through a probe. Some may also allow for reading phase and waveform measurements and may be able to be incorporated into a general-purpose multimeter.



*Figure 85 Clamp-on current probe*

## Insulated Rescue Hook



Left figure shows an image of an insulated rescue hook (may also be called a shepherd’s hook), which is an essential tool for technicians working near HV or on a BEB. This item is a utility tool that acts as an extension pole for you or another person to safely move or remove someone who may have been injured or incapacitated by a source of HV or electrical hazards. Because of the extended length of the hook, the person using it can maneuver the incapacitated person without exposing themselves to the same source of electrical hazard.

*Figure 86 Rescue hook (shepard's hook)*

## Fire Extinguisher

A standard fire extinguisher is a device that is a canister filled with materials and agents. When triggered by a person, it will expel said materials onto a source of heat or flames that offer a cooling or freezing effect. It can also act by smothering a fuel source or even removing any oxygen in that applied area. Oxygen is a fire’s main source of fuel, so removing any oxygen from a flame is necessary to reducing and putting out fires.

While most people are familiar with the standard fire extinguishers, there are also other types of multipurpose extinguishers that have additional categories and rankings. One such example that would be applicable for transit agencies is called an ABC fire extinguisher. This type is different because most standard fire extinguishers cover Class A fires, or those that would ordinarily involved common flammable materials like cloth, wood, paper rubber, or plastics.



*Figure 87 ABC-rated fire extinguisher*

ABC fire extinguishers offer fire reduction qualities not only for Class A fires, but also Class B and Class C fires. Fires categorized under Class B would involve combustible liquids like

alcohol, gasoline, and oil-based products. Fires categorized under Class C would involve anything with live electrical or energized equipment. Thus, ABC fire extinguishers are likely to be included at your agency if BEBs are going to be brought into the fleet. **One crucial aspect to point out is the ABC fire extinguishers have little effect on batteries that are experiencing thermal runaway event.**

## Phase Rotation Meter

A phase rotation meter is an instrument (meter) that shows the direction a three-phase motor would rotate when hooked up to a power source. Some meters will be able to indicated the orientation and whether a phase is live or not. These are typically used for verification of repairs, and by using this instrument to identify a phase, rotation and orientation, it will help with making motor adjustments and reducing or preventing damage to any electrical or motor system.

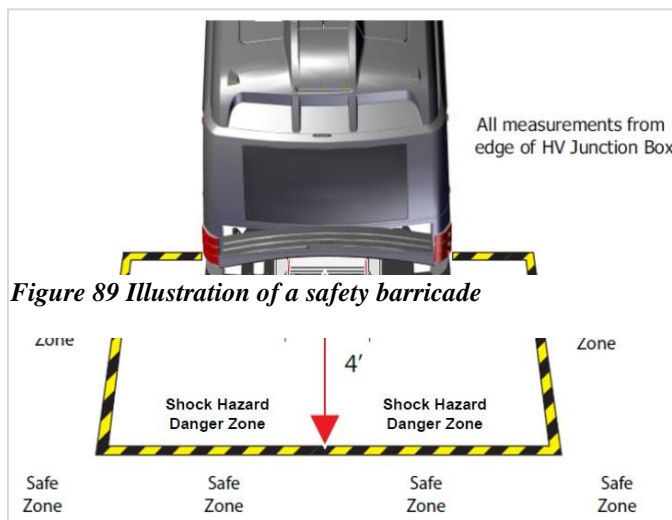


*Figure 88 Phase rotation meter*

## Safety Barricade

According to OSHA Standard 1926.968, a barricade would be considered “a physical obstruction such as tapes, cones, or A-frame type wood or metal structures that provides a warning about, and limits access to, a hazardous area.” The reason for setting up a safety barricade, particularly around the HV areas of a BEB, is to provide a physical barrier around the area being worked on.

The standard minimum distance to place the barrier is at least four feet (4') away from the hazard area. Cones may be used in place of barricades, and in some scenarios the safety observer may be responsible for keeping others outside the 4' zone when specialized equipment is not available.



*Figure 89 Illustration of a safety barricade*

## Insulated Tools

Insulated hand tools follow ASTM F1505-01 and IEC 900 standards. These tools are necessary for compliance with OSHA 1910.333 (c)(2), and NFPA 70E. They are often sold in kits and can include sockets, pliers, wrenches, screwdrivers, and torque wrenches (there are even insulated LED lights). It is important to have these insulated toolsets available in the shop, though it may not be necessary to be owned by every technician (stored away in a supervisor office or tool storage).

They often are sold in group kits. A toolkit could include (see figure):

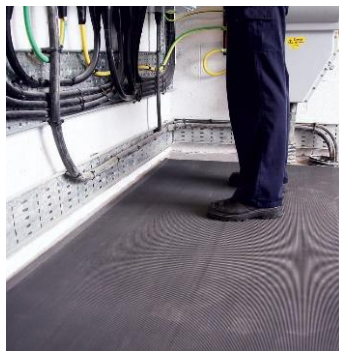
- Sockets
- Pliers
- Open End Wrenches
- Screwdrivers
- Torque Wrenches (3/8,1/4)

Such tools will be insulated like gloves, often double-insulated and will be tested and stamped with a test date. It is important to have a process in the shop for maintaining and retesting on the manufacturer's schedule. Vendors may (but not always) require specific tools for measuring voltages at specific locations. The right time to purchase these bus-specific tools is at the procurement stage. This can be negotiated as a part of the bus procurement negotiation as this assures the tools are available, often showing up before the buses do.



Figure 90 Sample insulated tool kit

### HV Insulated Mat



These items are a rubber floor covering or mat that offers protection and insulation in any given area you may find yourself standing in that puts you at a risk of running electrical hazard conditions. These mats are made with blended materials that are dielectric, meaning that the material has much higher internal resistance and integrity to withstand higher voltage output. These should be tested after approximately every 2 years.

Figure 91 High Voltage insulated mat  
– courtesy of COBA Europe

## 2-5 DE-ENERGIZING [LOCK-OUT/TAG-OUT] OF BEB ELECTRICAL SYSTEMS

Now that we've reviewed basic safety considerations and appropriate PPE for maintaining BEBs, let's get into the actual demonstration of de-energization (or Lock Out/Tag Out [LOTO]) of a BEB. For this section we can start to visualize the actual procedure and steps of performing a de-energization for specific bus models, including LOTO. For this, we have been able to partner with local bus agencies to record their own technicians performing this process – one showcasing the procedure for de-energizing of a Proterra 800-volt model, and the other demonstrating the de-energization procedure for a New Flyer model.

## Proterra Catalyst Demonstration

At this point, if you have either model of BEB on-site and available, your instructor will move you to an on-site bus for **Learning Applications 2F and 2G**. **However, do not focus on answering the questions but listening to what your instructor talks about at the bus.**

This will be an active demonstration of the agency Lock-Out/Tag-Out procedure. This process will vary depending on the bus manufacturer that is available.

In this section we will look at the Proterra example and feature a video demonstration of the de-energization/shut-down process for a particular bus manufacturer model.

---

### Learning Application 2F - Video review

Use the following link to view this video: <https://vimeo.com/775607506/a6ae5f6434>



After watching the de-energization process for a Proterra 800-volt ZX-5 model, read the following questions and answer each one. When you are finished, check in with your instructor for the answers, or view the video again.

- 
1. Where is the Master Switch located?

---

  2. Where is the Master Disconnect Switch located?

---

  3. What components do you need to apply multi-lockout tagout devices to?

---

  4. How do you determine that your voltmeter works properly?

---

  5. Do you need to verify the 12/24 VDC contactor has no voltage on either side of the contactor? What is the reference point?

---

  6. What is needed to be done in order to access the high voltage junction box [HVJB]?

---

  7. Describe the PPE testing the man performed.
-

- 
8. What is the voltage to be verified from the inlet busbars coming to the batteries?

---

  9. What is the verified voltage needed from the traction motor inverter connection and any HV components?

---

  10. What is the last part of the process?
- 

## New Flyer Charge Demonstration

---

### Learning Application 2G - Video review

Use the following link to view this video: <https://vimeo.com/775860389/b9d10f99bb>



After watching the de-energization process for a New Flyer model, read the following questions, and answer each one. When you are finished, check in with your instructor for the answers, or view the video again.

- 
1. What position should you set the Master Run Switch to?

---

  2. What should you do with the Battery and High Voltage Interlock switches?

---

  3. What needs lockout tagout devices in the rear curbside panel?

---

  4. Should you ensure there is no voltage on the 12/24 VDC battery bus bars?

---

  5. What do you measure between with your voltmeter inside the fuse box?

---

  6. How often should you inspect and/or test the HV gloves, and how?

---

  7. Which direction do you measure on the busbars?

---

  8. What do you measure from after you check between busbars?

---

  9. How do you determine if current is flowing through the manual service disconnect (MSD)?
-

10. How many MSDs do you remove?

---

**As mentioned at the start of this course, we have opted to include both Proterra and New Flyer as our manufacturers for this course. This is primarily due to the availability and location of their current bus fleet. While we currently have Proterra and New Flyer models as our video demonstrations, we are working on developing more content with additional bus manufacturers, including but not limited to: Gilleg, NovaBus and BYD.**

We advise you to check out other bus manufacturer models as they likely will have slight variations or model-specific items to address that you may not see covered in this section.

**Word of caution:** Any component or vehicle you de-energize could retain energy or voltage, even upwards of 10 minutes after being de-energized. As stated, always treat your work and any areas you work near or in as if they were live.

## 2-6 SUMMARY

Safety will always be critical for anyone working on a battery electric bus, no matter how much experience you have. However, it can become a lot easier to keep yourself and others safe while performing maintenance once you understand some of the fundamental electrical concepts while also keeping in mind the practical safety considerations that help reduce the likelihood of hazards such as arc flashing and thermal runaway, the importance of lockout/tagout/de-energization, built-in safety features and standard regulations of electric vehicles, and emergency response protocol and personnel.

We also introduced the categorization of the types of PPE you will need for working on BEBs and reviewed the specific testing and additional safety equipment that are often used in the shop. Lastly, we showcased two specific video demonstrations of the step-by-step process to perform a de-energization/LOTO procedure for two manufacturers' models.

Sources:

1. Proterra
2. New Flyer
3. Gillig
4. Alexandria Transit Company [DASH]
5. DC Circulator
6. Immersed Technologies
7. Mitsubishi
8. [High Voltage Safety – Safety – UW–Madison \(wisc.edu\)](#)
9. [High Voltage Vehicle Safety Systems and PPE \(sae.org\)](#)
10. [Arc Flash \[Facts, Safety Requirements & PPE\] \(creativesafetysupply.com\)](#)
11. [How to Keep Safe from Arc Flash: A Guide | SafetyCulture](#)

# MODULE 3

## *Battery Charging Technologies*

### Outline

- 3-1 Overview
- 3-2 Charging Overview
  - 1) Describe the three primary charging methods for BEBs
  - 2) Calculate an anticipated charge time for each method of charging
- 3-3 Electric Vehicle Charging Standards
  - 1) Explain the purposes of standards SAE J1772, SAE J3105 and SAE J2954-2
- 3-4 Details of Charging Technologies
  - 1) Explain the general process of how a charger and battery communicate
  - 2) Identify the purpose of a switchgear
  - 3) Define smart charging
- 3-5 Brief Charging Precautions
  - 1) List at least three opportunities for emerging charging technologies
  - 2) Describe safety precautions for charging equipment
- 3-6 Summary

### Learning Outcomes

This module introduces the different charging methods for BEBs, current and emerging technology to improve quality, SAE charging standards, and charger maintenance and charger equipment safety precautions. Following the completion of this module, the participant should be able to complete the outcomes with an accuracy of 80% or greater.



### 3-1 OVERVIEW

Many concerns should be considered when determining what charger to select for your agency, including, but not limited to: maintaining and meeting service needs, power capabilities, infrastructure, etc. This module will cover charging options and considerations, charging and battery management, typical charging times, and the aim of future advancements.

Let's introduce some additional terms that you may see throughout this module. Some terms you have already seen throughout this course, but newly introduced are terms specific to what we will cover in the discussion of charging technologies.

|  |                                |                                 |
|--|--------------------------------|---------------------------------|
| AC- Alternating Current                  | BMS- Battery Management System | AC Charger- Inverter on vehicle |
| CCS- Combined Charging System            | Conductive Charging            | DC-Direct Current               |
| DCFC – DC Fast Charging                  | Depot Charging                 | ESS- Energy Storage System      |
| EVSE – Electric vehicle supply equipment | Inductive Charging             | Kw- Kilowatt                    |
| kWh- kilowatt hour                       | Opportunity/On-route charging  | Overnight Charging              |
| Smart Charging                           | State-of-Charge [SOC]          |                                 |

### 3-2 CHARGING OVERVIEW

#### Various Charging Options

Let's start this section with an overview of charging suppliers and options that can be available currently.

#### Transit Bus Charger Suppliers

## COURSE: BATTERY ELECTRIC BUS FAMILIARIZATION

There are a variety of charger manufacturers of all types out there, and this figure below shows the logos for many major manufacturers for transit bus type applications, ranging from ABB and Siemens to ChargePoint, Heliox and more.



Figure 92 Major BEB manufacturers

Two of the current suppliers listed—Momentum Wireless Power and Wave—are manufacturers of wireless inductive charging. They are in the process of conforming to the SAE J2954-2 Standard, which is still under development (more on this in Section 3-4). Power Electronics is also soon to be added to this list.

### Charging Options

There are several primary methods of charging to be used for BEBs. Both of the following options can be designated as “depot charging” It can be up to your discretion if you would like to clarify this to the participants.

1. Plug-In – A means of charging with a unit at the depot (agency). Initially, depot charging was an AC charger that was used to replace the diesel fuel nozzle and is widely used overseas, typically in Asia and parts of Europe.
  - a. With an AC charger, the inverter is on the bus, so you will have a smaller unit. Sometimes it’s pedestal wall-mounted. However, recent advances for interoperability are increasing for DC or DC Fast chargers, and they typically can charge much sooner, much quicker.
2. Overhead DC Charger - An overhead DC charger has the inverter in the converter [DC], so it will have a bigger cabinet and be more expensive (but that is fine with BEBs). The trade-off is that is that it can charge faster and requires less time to charge, while taking some weight off the bus.
  - a. DC chargers are becoming the norm because they offer interoperability and are UL listed. As depot stations/other properties start to realize and consider some of



## COURSE: BATTERY ELECTRIC BUS FAMILIARIZATION

the challenges with charging, they are looking at other technologies to reach a complete fleet solution.

3. Other (Overhead or Inductive) – These include up-and-coming technologies that are being studied and tested sparingly. Examples include on-route charging, inductive charging pads, and overhead charging, as well as variations to these technologies. They also have other considerations for being implemented, such as ease of use in the facility, ease of maintenance/space, charging needs, etc.

- a. Overhead –

- i. This is done via overhead using a roof-mounted pantograph charging system. An overhead pantograph typically will incorporate a power distribution box and a means of charging, as the image shows.



*Figure 93 Overhead charging in use example*

- ii. This includes pantograph down or pantograph down styles, where the pantograph comes down and charges the bus. The top of the bus will have rails to accept the power. Overhead chargers are typically pantograph up or down style. This charging method usually requires less battery capacity as charging more frequently occurs on the route.

- b. Inductive (wireless) charging –

- i. This is done via electromagnetic induction, and is a relatively new emerging technology that has been gaining popularity. Several solutions are being used and considered presently and planned for the future,
- ii. The technology consists of a wireless charging station in the ground (a pad) and with pads on the bus as well.
- iii. Included some challenges and concerns early on, mainly with efficiency. Currently, efficiency is around 90% plus, sometimes 95%. Most of those challenges and concerns have been addressed, particularly the transfer of power.
- iv. The increase of available charging kilowatt rates has gone from 75 kilowatts to 150 kilowatts, to currently 300 kilowatts, with plans for looking at higher kilowatt ratings for the future. Opportunity charging



*Figure 94 Example of a wireless charging bus*

## COURSE: BATTERY ELECTRIC BUS FAMILIARIZATION

presents many benefits and mainly these are 1-to-1 fleet replacement, and no concerns for range.

### Charging Times

Now let's review and show the relationship between battery capacity and charging times. Charging times will vary by battery capacity. Charging times (in hours) is a function of battery capacity and charging power. The formula for establishing charging times is simply charging times (rated as H in hours) equal to battery capacity kilowatt hours divided by effective charging power, or kilowatts.

**Please note** that there are other factors that may influence charge times, factors that include: heat, energy demands or pre-conditioning (cold temperatures) and wear, and battery chemistry. For this module we are determining an anticipated charge time.

$$\text{Charging Time [h]} = \text{Battery Capacity [kWh]} / \text{Effective Charging Power [kW]}$$

Charging times also vary by charging method and with the formula mentioned. Let's take a look at some examples:

- AC Depot Plug-In Charger (80 kW)  $x = 320\text{kWh}/80\text{kW}$  // therefore  $x = 4$  hours
- DCFC Depot Plug-In Charger (150 kW)  $x = 320\text{kWh}/150\text{kW}$  // therefore  $x = 2.5$  hours
- Pantograph Charger (300 kW)  $x = 320\text{kWh}/300\text{kW}$  // therefore  $x =$  roughly 1 hour
  - Since this method of charging is for “topping-off” or extending range, a six-minute charge will put roughly 30kWhs back into the battery pack, which should be roughly 15 miles
  - In theory, if you were utilizing an on-route charger every 20 miles or so, you should see long range/use, or you can also look at hours miles per hour travelled and factor this way. The best case is an opportunity charger being used on a “loop-service,” which allows for less battery pack (kWh) requirement.
- Wireless Charging (150 kW)  $x = 320\text{kWh}/150\text{kW}$  Therefore  $x =$  Roughly 2 hours or (using factors above) adds roughly 15kWhs of power back into the battery pack.

**Please note that we are assuming the examples are being done with a new 400 kWh battery pack and charging from 20% State of Charge [SOC] to 100% SOC (80kWh to 400kWh Capacity). Each battery (chemistry) may have different charging requirements per charging rate of allowed power.**

### Learning Application 3A

Using the formulas given to you in the previous section, calculate the estimated charging times for the following examples:



1. An AC Charger with a battery capacity of 240 kWh and an effective charging power of 60kW
2. A DC charger with a battery capacity of 400 kWh and an effective charging power of 50 kW
3. Pantograph or overhead charger with a battery capacity of 400 kWh and an effective charging power of 100Kw
4. Wireless charging battery capacity at 360kWh and an effective charging power of 120kW

---

## 3-3 ELECTRIC VEHICLE CHARGING STANDARDS

There are a number of standards that come into play with dealing with BEBs. The most commonly quoted standards are the ones that we're looking at here, and these are contact or plug-in. Standard shop connections are there to allow for mixed OEM fleet deployment, but what we're looking at for most of the connections here are:

1. **J1772** – This is a standard plug-in (currently most common depot application in North America). Provides communication and charging connections in one form.
2. **J3105** – This is an overhead charging standard, which applies to any of the conductive overhead charging or the pantograph charging we covered. Typically, it is a fixed charger arm that moves into position and couples with the bus.
3. **J2954-2** – This covers the inductive or contactless charging.

There is also standard J3068, but this is actually more for AC charging and not very applicable currently.



Figure 95 Primary logo for SAE standards for charging

### Standard J1772 (Plug-In Charging)

As mentioned, standard J1772 is likely the one you are most likely familiar with if you've come across electric charging (depot charging specifically). It describes the electrical and physical interfaces between the vehicle and supply equipment to facilitate conductive charging in a plug-in configuration. This does cover AC and DC charging capabilities (mostly DC for transit operations and heavy-duty vehicles).

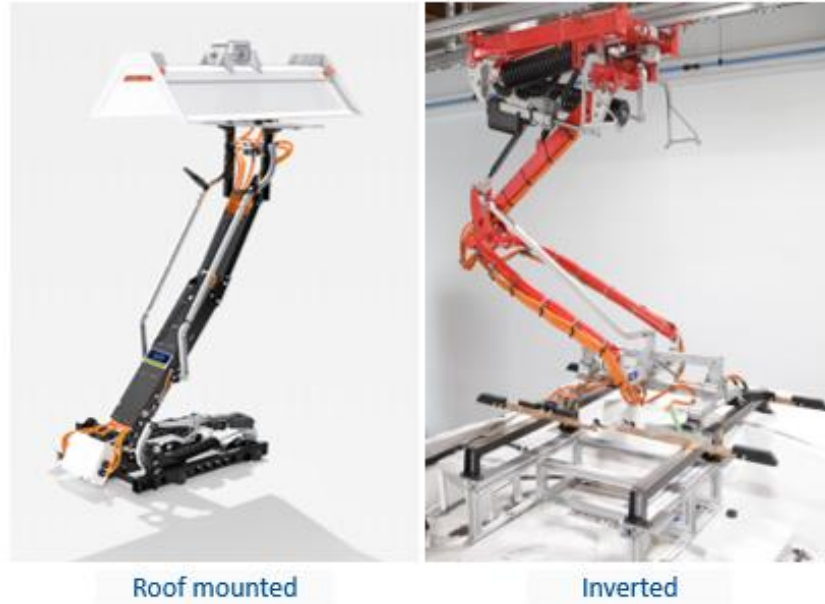
The J1772 standard includes several levels of shock protection, ensuring the safety of charging in the event of wet conditions. Physically, the connection pins are isolated on the interior of the connector when mated, ensuring no physical access to those pins. When not mated the J1772 connectors have no power voltages at the pins and charging power does not flow until it is commanded by the vehicle. Again, it is safe to touch that plug or either the connector on the opposite side without coming into contact with high voltage there.

Something important to note is that the ground pin is of the first make/last break variety. If the plug is in the charge port of the vehicle and charging, and it's removed, the shorter control pilot pin will break first, causing the power relay to open then stopping the current flow. This prevents any power arcing on the power pins and makes it safe for you to come into contact with this. If you accidentally knock into the charge head or charge port on a J1772 connector, that will immediately break the circuit and stop the charge.

### Standard J3105 (Overhead Charging)

## COURSE: BATTERY ELECTRIC BUS FAMILIARIZATION

Standard J3105 is our overhead pantograph charging option. We have two that are most common in the industry: the roof-mounted pantograph (which is bus-up) and the inverted pantograph (or bus-down). This allows for on-route and depot charging options at higher charging capacities, currently roughly up to about 600 kilowatts.



*Figure 96 Example pantographs for charging*

The roof-mounted overhead charging options allow for the option to install more powerful chargers for a faster charging time. As we continue to refine this charging technology you may see that 600-kilowatt max increase based in what happens with the revisions to the 3105 standard. These systems typically allow for connection and charging of the vehicle battery in a shorter time frame than plug in chargers and can be utilized while the vehicle is on a revenue service route or at a base and can be connected without the operator leaving the seat.

Overhead or depot charging conforms to the SAE J3105 standard, also consistent with upcharge, which was developed in Europe by various manufacturers. The charging method here (a pantograph down type design shown) is currently the more commonplace method for BEB facility charging. Overhead charging can be done in a depot for charging a bus without anybody having to plug in a plug-in connector, but it's typically used for on-route charging. This type of example – other than parking underneath the pantograph – is done automatically so the driver does not have to do a lot of routine work to initiate the charging session.

There are three types of overhead charging that are permitted, including various methods for making contact and transferring power to the bus. With this particular example, there are charge rails located on top of the bus, and the pantograph will come down from the overhead mast and make contact with the charge rails.

These chargers can be placed both indoors and are also typically placed in an outdoor environment and have to be conducive to operating in cold and hot weather and can be a challenge if not planned properly. They can also be designed to be universal, meaning that they

can be integrated at any location. Understanding what these specifications are for the charger determines how it will be used and the provisions for how it will be housed. There is a system called NEMA 3R, which is an outdoor rating for chargers to withstand certain weather conditions.

### Standard J2954-2 (Inductive Charging)

Standard J2954-2 is out there, but this is an emerging technology that covers your inductive charging. This allows for both on-route and depot charging options. With it we have windings built into the road surface that generate an electromagnetic field. These electromagnetic fields that are generated will interact with a receiver built into the floor of the bus that turns the electromagnetic field into energy that can be supplied to charge the energy storage systems.

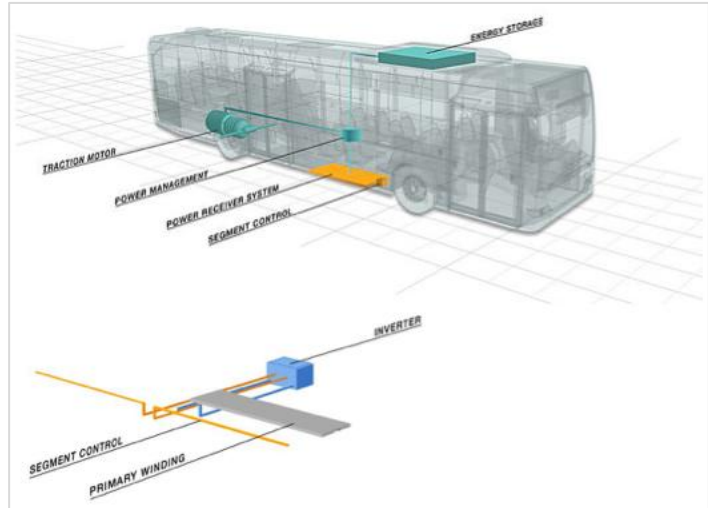


Figure 97 Diagram of an inductive charging bus

This process is similar to the inductive charging technology used on most modern cell phones, so charging your most recent iPhone is one example. If you use inductive charging technology for a phone, you use the same standard. A transit application is much bigger, as you will have higher duty cycles and it does a much more efficient job at charging the bus compared to a phone.

If you are wondering whether it is possible to come into contact with high voltage when looking and handling inductive charging technologies, the answer is no. What would happen is if those windings were to fail at any point, the circuit is disconnected and there would be no possibility of you coming into contact with that high voltage. This is because it all exists below the asphalt. However, J2954-2 is still in development. It's not a released standard, but SAE continues to work with various stakeholders (including Momentum Dynamics and Wave on finishing that standard).

## 3-4 DETAILS OF CHARGING TECHNOLOGIES

Let's begin reviewing charging and battery management-communications between bus batteries and the charging equipment.

### Battery and Charger Communications

Charging management is referring to the management of the vehicle charging (the hand off of connecting your charger to the bus, which could be a plug in or pantograph or inductive charging). Smart charging technology allows the ability to monitor and control charging. Let's take a look at how the cycle of communication between the battery and charger actually occurs.



## COURSE: BATTERY ELECTRIC BUS FAMILIARIZATION

1. First off, a ground sensing circuit is built into both the vehicle charge port and the **charge cable**.
2. Vehicle and charger share information on: **operating voltages**, SOC (state of charge), charger capabilities (output), **charge parameters** of vehicle (max current and for how long), and current status of HV systems (faults)
3. Charger and vehicle perform an **isolation test** (failure of this test aborts charge sequence)
4. The powertrain is then automatically disabled once this sensing circuit is active. Once the handshake is initiated, a “**powertrain inhibit**” signal is sent to the powertrain controller to keep the vehicle from driving away.
5. Then the **control pilot** functions begin. This is when the supply equipment detects the BEB. The supply equipment then indicates exactly its readiness and whether or not it’s able to supply the energy.
6. The BEB ventilation and cooling requirements are determined, which is important for both the bus and charger to understand. Then, the **supply equipment current capacity** is provided to BEB.
7. After the tests pass the vehicle signals the charger to begin charging (charge controller on vehicle **always** has final control of charge sequence
  - a. Contactors in the charger close and charger supplies current to vehicle
  - b. Charge contactors on vehicle close and allow charger to supply charge current

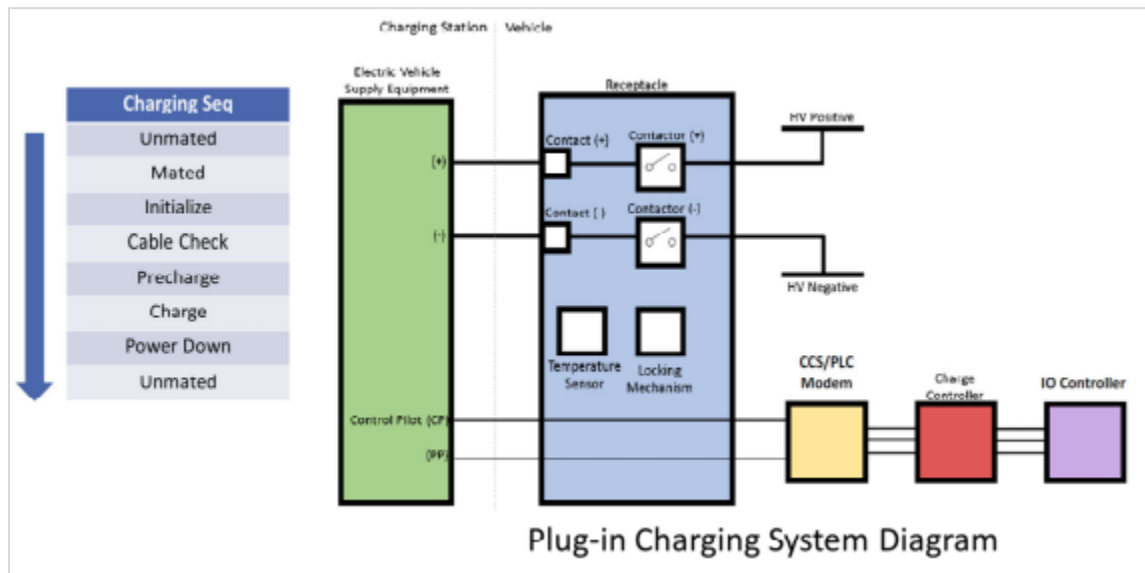


Figure 98 Plug-In communication system diagram

The figure above illustrates the general process of the cycle of charging communication between battery and charger. **Until this point, there is no high voltage present at the charge cable.** It is not possible for you to come into contact with high voltage when plugging in the charger, even if

rain or other severe weather is present. During the charging process, high voltage isolation and other parameters are continuously monitored, and if at any point a parameter exceeds the specified limits in the programming, the charge sequence is automatically ended.

What to look for here is if there's any isolation breakdown. This means we see if the high voltage circuit has come into contact with anything other than its own circuit, it sees that the isolation has broken down and therefore the charge is automatically ended. While the charge is actually happening, the BEB is controlling the command charge, so at no point does the charger have any control other than supplying the power to the BEB. You can always interrupt the charging sequence by pressing the "End charge" push buttons or e-stops on any of the chargers. Outside of that, the charge will continue as long as the bus is pulling for or asking for a charge.

New advancements in technology for charging and battery – particularly in the Northeast – have now allowed for the ability to condition a bus before it goes out in cold mornings. When the operator leaves for service, their bus interior temperature is controlled and the batteries are at 100% state of charge.

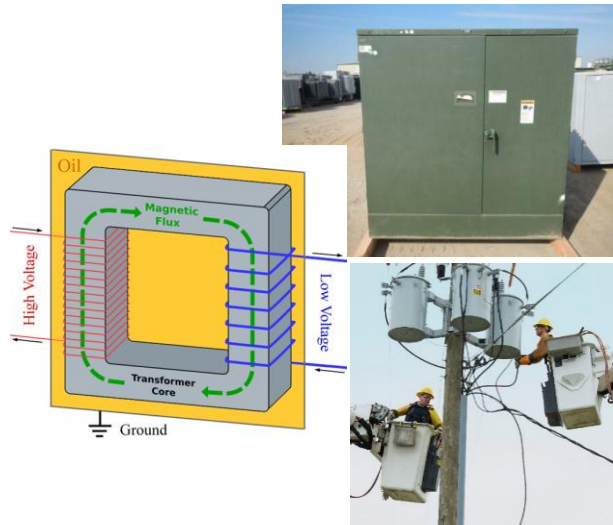
At this point, if available your instructor will move to **Hands-On Exercise 3B**. This will be an active learning demonstration of the charging communication sequence with the bus (connect and disconnect). If this is available, your instructor will hand out the exercise and ask you to follow along with the demonstration.

## Transformers and Switchgears

You may already be familiar with transformers and switchgears, but this will be a brief review of both and how they factor into charging technologies.

### Transformers

A basic definition dictates that a transformer is a device that can transfer electrical energy from one electrical (AC) circuit to another circuit (or even multiple) while either increasing, decreasing or maintaining the same voltage. Transformers can come in different types and sizes and are a very important part of setting up the infrastructure for the charging.



*Figure 99 Examples of transformers*

Transformers can take the form of a pole-mounted transformer (as shown below) or they could be in a cabinet, at the transit depot, or wherever the charging equipment is going to be located. Along with the transformers is typically a meter that the utility company will set up. Referring to the electrical basics from M2, keep in mind Lenz's Law where conservation of energy means it can only be changed or transformed applies to the transformer and how we use it for charging.

This is a very important consideration for both short-term pilot type projects and the longer-term vision of what the capacity is going to be at a various transit bus depot. Make sure your utility company is involved with helping

determine what would be necessary, both short-term and long-term, regarding transformers and metering.

## Switchgears

Another necessary part of the infrastructure that goes along with chargers is switchgear. A switchgear is a device in an electrical system made up of electrical disconnect switches, fuses and/or circuit breakers to monitor, control, protect and isolate electrical equipment in a surge event. It is essentially a switch on a larger scale, and the first point the power touches in the circuit. This device can be an individual switch to dis/connect grid voltage from a circuit, series of switches, fuses or circuit breakers.

If triggered during a surge, the switchgear automatically interrupts the power flow which helps protect any electrical systems from damage.

The figure on the right is one form a switchgear may take.

There are various forms and factors and technicians are probably familiar with switchgear at their depot locations, and may not exactly look like this. But this is what a typical

switchgear setup might look like at many facilities. The importance of a switchgear is that you are able to energize and de-energize the charging equipment safely. This is something that needs to be well understood by technicians and take safe precautions when servicing the charging equipment.



*Figure 100 Example switchgear*

The figure below demonstrates a typical example of what the wiring might look like from the transformer to the switchgear. There are six chargers and twelve dispensers as shown in the photo. This can be scaled accordingly, but in this example it could be designed for future expansion or for something that is dedicated toward the design.

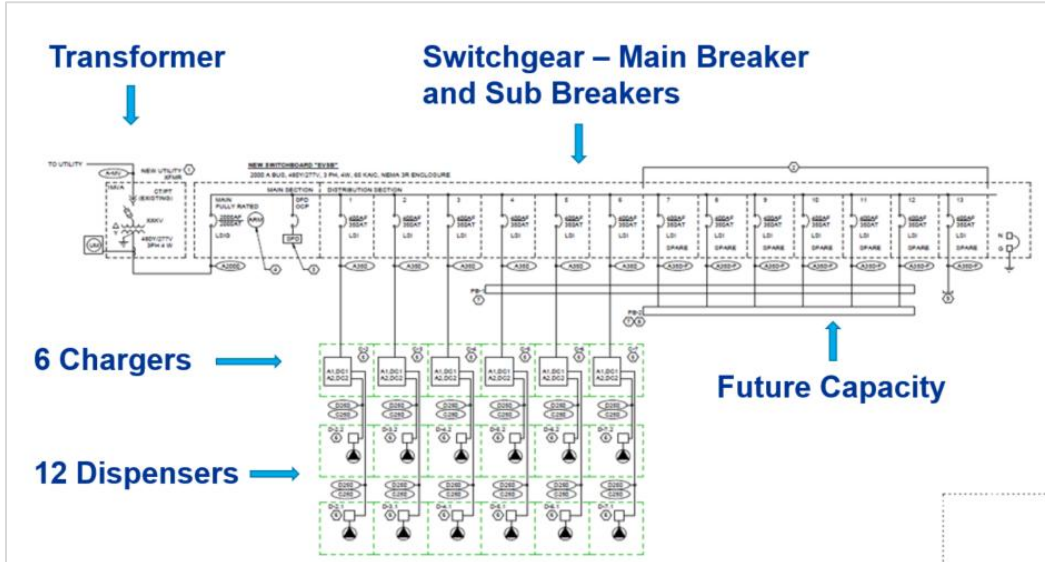


Figure 101 Wiring diagram of transformer to switchgear

While it is important to understand what transformers and switchgears do, as a BEB tech it may not fall within your duties to maintain the charger, charging equipment and systems. This is possible, but the expectation does not make it necessary, nor does it currently fall in this familiarization course structure.

## Emerging Charging Technologies

### Smart Charging

One separate emerging technology is smart charging, and it is relatively new to the industry. The concept has been around, but we are starting to see more and more deployment of smart charging, especially as the infrastructure gets larger and the charge management system becomes more complex through things such as multiple dispensers.

Smart charging:

- Ensures that all vehicles are charged

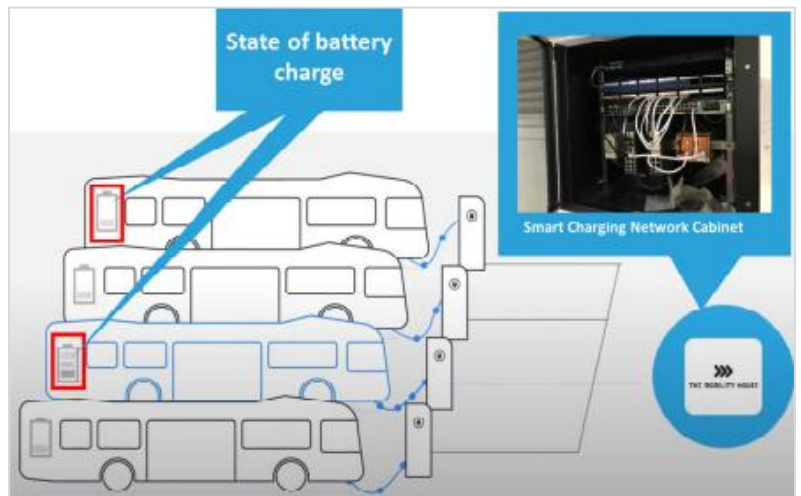


Figure 102 Diagram of model smart charging depot

## COURSE: BATTERY ELECTRIC BUS FAMILIARIZATION

- Limits peak demand charges based on software parameters.
- Prioritizes specific vehicles, in cases of when a vehicle comes into the depot or which vehicle has the lowest state-of-charge [SOC]
- Reports charging data and vehicle status
- Provides alerts in case of charge failure

Smart charging is important because it helps manage the optimum charging time of the buses as it pertains to demand charges and time-of-use charges that the utility company may impose on various charging applications. If you've got a large fleet of vehicles and they all pull in at certain times, smart charging will allow the user to determine an algorithm that makes sense for them on how the transit agency would prioritize charging the buses. Some buses may need to go out sooner rather than later, and with that preprogramming, the transit agencies can prioritize how these vehicles would be charged in a large fleet.

### Simultaneous vs Sequential Charging

Under smart charging, there is also the two methods of simultaneous charging and sequential charging. Simultaneous charging is a method of smart charging that can allow two or vehicles connected at once. As such, one charger can have multiple connection points to a bus, and this allows for the charger to charge all the vehicles connected to the charger at the same rate though the output will be determined by the total number of buses connected.

Sequential charging is the charging method that counters smart charging. Sequential charging is the charging method that counter to smart charging. This method prioritizes one vehicle at a time. This will be dependent on when a vehicle comes into the depot or the vehicle that has the lowest state of charge [SOC]. One charger here will prioritize one battery at any given moment.

We will see more smart charging technologies out there as part of the emerging infrastructure and the overall planning of infrastructure for the electric buses. The group to the right includes a photo of an actual smart charging cabinet (courtesy of ABD) and a 3D simulation of a smart charging bus depot.



## Other Emerging Charging Technology and Opportunities

Across the industry we are both using and continuing to improve current methods such as:

- Some locations repurposing existing overhead cabling as was used with electric trolleys (which may work in some cities, some applications)
- Solar panels on roofs of buses to offset or assist with electric demand from the HVAC system. The HVAC system has a good demand on the battery (particularly with all electric heat), so if we can offset that with solar panels on the bus roofs, that would be a great innovation.

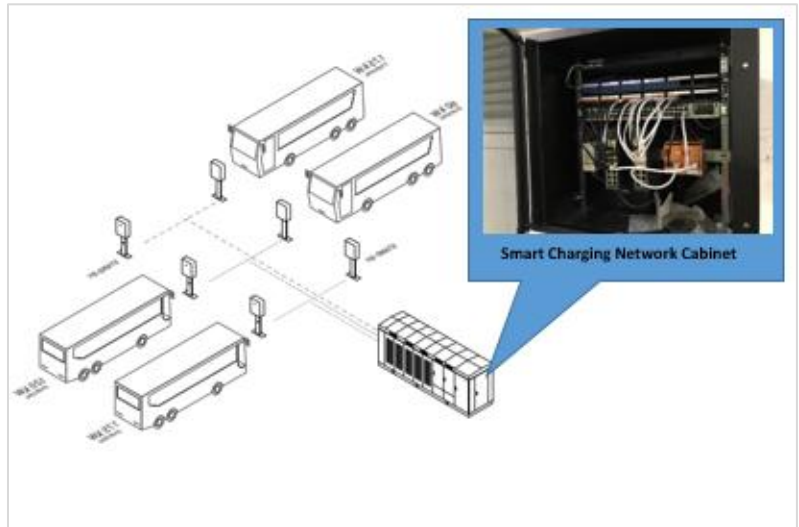


Figure 103 Example models of smart charging depots - courtesy of ABD

What are some of the charging technologies looking like down the road? As we start to grow fleets and implement BEBs, many new innovative technologies and strategies will be implemented and tested. You will need to keep in mind what considerations are necessary for charging.

What will the future hold for EVs & BEBs, particularly with continued growth, charging, batteries, and range? Ideas being used, worked on and considered:

- Vehicle-to-grid (V2G) is a hot button topic right now for emergency power (to help you with your peak demand).
- Wireless electrified roads
  - One major advancement is being made in terms of electrification segments of roads to enhance inductive charging methods. The bus will go down the road and be charged much the same as inductive charging
  - Examples include Sweden (has started and plans to expand to the whole country), South Korea (since 2017 it has been testing [7.2 miles] as well as Tel-Aviv [1.2 miles])
- Remote wireless charging
- Solid state batteries – they improve batteries and life of batteries
- Ultra-fast carbon electrode technology (NAWA Technologies)
  - Uses a vertically-aligned carbon nanotube design to boost battery power tenfold, increase energy storage by a factor of three, and increase the life cycle of battery five times.

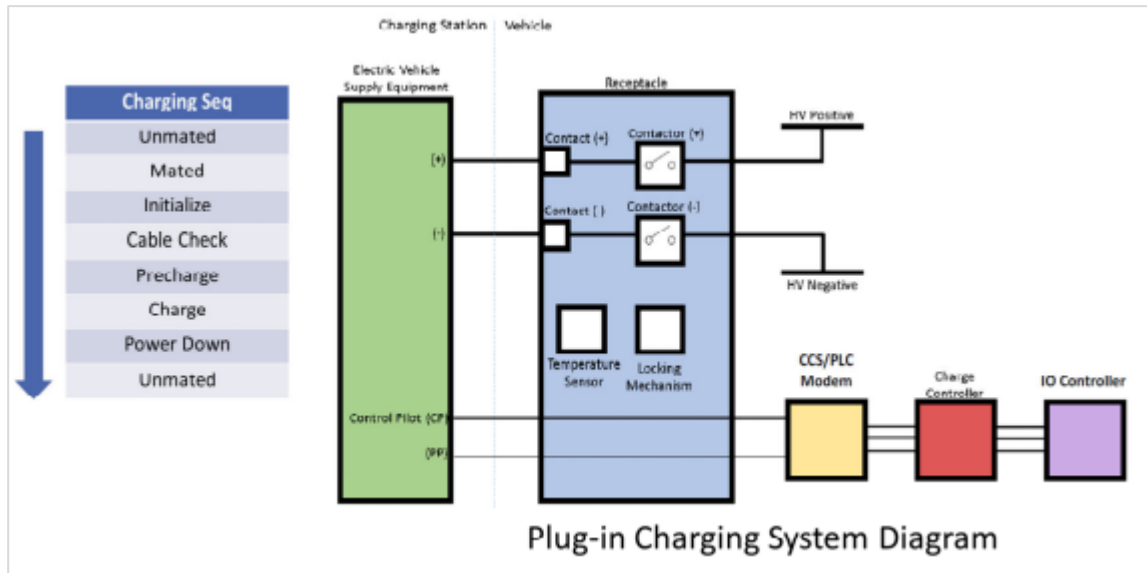
**COURSE: BATTERY ELECTRIC BUS FAMILIARIZATION**

- Semi-conductors, ultra-fast charging (allows for less downtime and improves EV appeal and management) and nanowire battery technology (faster charging and longer life)
  - The goal is to go farther on a charge. We want to get electric buses equal to what we can get out of a diesel engine/tank.

**Learning Application 3C -**

Using the phrases below, write out and identify the blanks in the process of a charger-battery communication sequence. You may also find another participant to practice/quiz you on how many you can write/fill in.

Word bank: Charge cable, operating voltages, charge parameters, isolation test, “powertrain inhibitor”, control pilot, supply equipment current capacity, contactors, vehicle



1. First off, a ground sensing circuit is built into both the vehicle charge port and the \_\_\_\_\_.
2. Vehicle and charger share information on: \_\_\_\_\_, SOC (state of charge), charger capabilities (output), \_\_\_\_\_ of vehicle (max current and for how long), and current status of HV systems (faults).
3. Charger and vehicle perform an \_\_\_\_\_ (failure of this test aborts charge sequence)
4. The powertrain is then automatically disabled once this sensing circuit is active. Once the handshake is initiated, a “\_\_\_\_\_” signal is sent to the powertrain controller to keep the vehicle from driving away.

5. Then the \_\_\_\_\_ functions begin –this is when the supply equipment detects the BEB –the supply equipment then indicates exactly its readiness and whether or not it’s able to supply the energy.
6. The BEB ventilation and cooling requirements are determined, which is an important thing that both the bus and charger need to understand. Then the \_\_\_\_\_ is provided to BEB.
7. After the tests pass the vehicle signals the charger to begin charging (charge controller on vehicle **always** has final control of charge sequence
  - a. \_\_\_\_\_ in the charger close and charger supplies current to vehicle
  - b. Charge contactors on \_\_\_\_\_ close and allow charger to supply charge current

---

## 3-5 BRIEF CHARGING PRECAUTIONS

**As the charger and its required maintenance may be a part of the infrastructure at your agency, you may not need to handle the actual charger maintenance and upkeep. If this happens at your agency the expectation is that you may encounter situations where you are asked to perform charger maintenance. This typically does not fall under the expectations for the job classification for BEB maintenance.**

### Charger Safety Precautions

This section will point out brief precautions to keep in mind should you have to perform inspection and/or maintenance on charger equipment.

To start with some basics for safety precautions when managing or working on chargers:

- **Make sure to disconnect all input and output sources and use proper caution before opening or working on any equipment.**
  - Everything is infinitely safer if you know the equipment is off and you’ve verified the absence of voltage with the proper measuring instrument.
- **DC link capacitors can hold a charge after being disconnected from the grid and DC input.**
  - You want to make sure you verify that you wait the proper amount of time based off of what any of the OEMs recommend, and can be anywhere from approximately 10 to 15 minutes (give or take) to make sure that the DC link capacitors have bleed down.
  - This can actually become a shock hazard, or even an arc flash hazard depending on how they are integrated into the circuit.
- **Remove your jewelry – any watches, rings or metal objects from your person.** You don’t want to give any of the power an easy path to ground, or give an easy path towards ground through you which becomes a shock or arc flash hazard.
- **Be sure that all electrical connections and connectors are installed and properly torqued.**



## *COURSE: BATTERY ELECTRIC BUS FAMILIARIZATION*

- If you have a loose high voltage lug it adds to the resistance in the circuit, then generates more heat and the possibility for thermal events.

### **Charger Safety Precautions - PPE**

To properly service any charging equipment, you will need certain PPE. This would include:

- Arc flash suit
- Arc flash face shield with a hard hat
- A balaclava or arc flash hood
- Safety glasses and earplugs or inserts
- Rubber-insulated gloves with leather overlays
- EH-rated safety shoes.

We have introduced these particular PPE items in Module 2, so it should be familiar to you. You can refer back to this section if you need a reminder on the specific uses or what these PPE look like.

Some of the tools and equipment that you need as well can include:

- An appropriately rated digital multimeter (or DMM, you may also see this shortened to DVOM-they're just interchangeable in this case)
- Lock-out devices
- Replacement tools like breakers for the switchgear (you will need one for the charger and one for the dispenser)
- You may need multiple charge cables, especially if you're about to work on any of these smart charging systems
- Anti-static wrist strap - if you're servicing any of the electronic components. You don't want to accidentally discharge even a little bit of static electricity on any of these circuit boards, as they are controlling the high voltage at very strict tolerances.

It is important to note that some items- such as the charge cables and breakers- are replacement components rather than tools. While not necessarily considered tools or equipment, you will also need a safety observer with the same level of PPE. You will need someone there that is keeping an eye on what you're doing, so if you accidentally come into contact with voltage, they are there and able to pull you away. If there is an arc flash event, they can make sure that they can get you to safety.

## **3-6 SUMMARY**

BEB charging is a lot more than just plugging in a charger or having a bus drive into the shop and begin charging through the pantograph. There are multiple options for BEB charging, and each comes with its own charging standard for safety and consistency across the industry. Charging maintenance seems straightforward, but you should still always keep your guard up as there are still lots of things that could result in danger to you or those around you. There are also a lot of new charging technologies and considerations coming down the pipeline, so keep an ear and eye out for when these go live or can be installed to see how they perform in the real world.

Sources:

1. DASH
2. DC Circulator
3. Proterra
4. New Flyer