



# Battery Electric Bus Familiarization



## Module 2: **Electrical Safety & Personal Protective Equipment**

# Overview

Overview

Safety Considerations







Personal Protective Equipment (PPE)

Safety & Testing Equipment







De-Energizing or LOTO [Lock-Out/Tag-Out] of BEB Electrical Systems

Summary

# Learning Outcomes

-  Recall the formula for calculating voltage
-  Define high voltage risk and shop safety conditions
-  Recall the SAE standards pertaining to BEBs
-  Identify primary built-in safety features and recall their function
-  Identify typical PPE involved with BEB maintenance
-  Recall the primary functions of each PPE introduced
-  Recall the procedures for testing and inspecting HV gloves

# Learning Outcomes

-  Explain the purpose of the appropriate safety and testing equipment
-  Identify when to use the appropriate safety and testing equipment
-  Recall the proper de-energization procedure for an 800-volt Proterra bus
-  Demonstrate the ability to perform a LOTO on an 800-volt Proterra bus  
(only applicable to in-person training with qualified personnel)
-  Recall the proper de-energization procedure for a New Flyer bus
-  Demonstrate the ability to perform a LOTO on a New Flyer bus  
(only applicable to in-person training with qualified personnel)

# Overview (50)

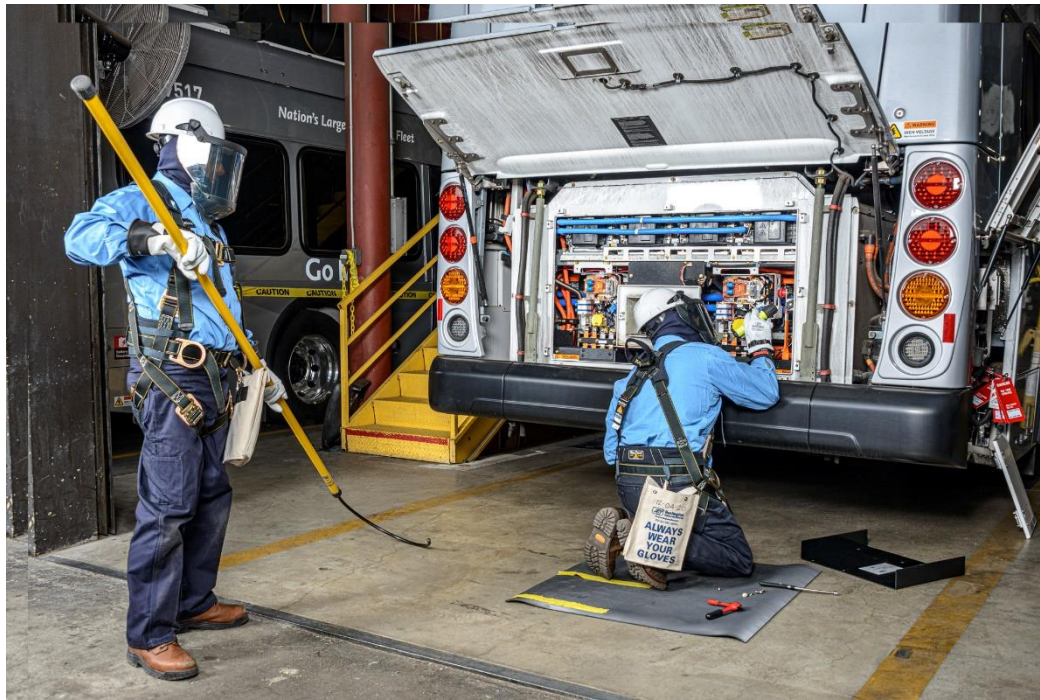

- DC voltages on BEBs run as high as 800VDC, and there are multiple sources of energy
- Buses may look the same but this is very different setup from standard 24VDC starter batteries and diesel engines.
- As a reminder, this course session is not intended to be a replacement for a full-course on HV safety, but instead it should act as introduction to worker safety

# Overview (50)

1. **OSHA** [Occupational Safety and Health Association] Standards 1910-302-308, deal with electrical systems, not limited to vehicles, and related standards for safety
2. **NFPA** [National Fire Protection Association] Standards 70B and 70E are two examples of best practices when dealing with electrical systems.
  - a. Also provide first responder training
3. **IEEE** [Institute of Electric and Electronics Engineers]
4. **FMVSS** [Federal Motor Vehicle Safety Standards]
5. **NHSTA** [National Highway Traffic Safety Administration]

**SAE**  
INTERNATIONAL  
SAE-J1772  
SAE-J3105  
SAE-J2954



# Section 2-2: Fundamentals & Safety Considerations



# Electrical Fundamentals & Laws (51)

**Voltage:** pressure from an electrical circuit's power source that pushes the charged electrons (or the current) through a conducting loop, enabling them to do work

- Most common automotive voltages are 12V and 24V output

**Current:** rate at which electrons flow past a point in a complete electrical circuit

- Any differences in potential can create a source of current. Electrical flow needs a path so if there is no set path then there will be no current

**Resistance:** opposition to current flow in an electrical circuit.

- **Insulators:** materials with a high resistance value - current has a more difficult time flowing through that path
- **Conductors:** materials with a low resistance value - more easily allows current to flow through (opposite to insulators)





# Electrical Fundamentals & Laws (52)

**Ohm's Law:** formula for relationship b/w aspects of electricity

Standard formula is  $V = I \times R$

**V = Voltage**

**I = Current**

**R = Level of resistance**

## OHM'S LAW

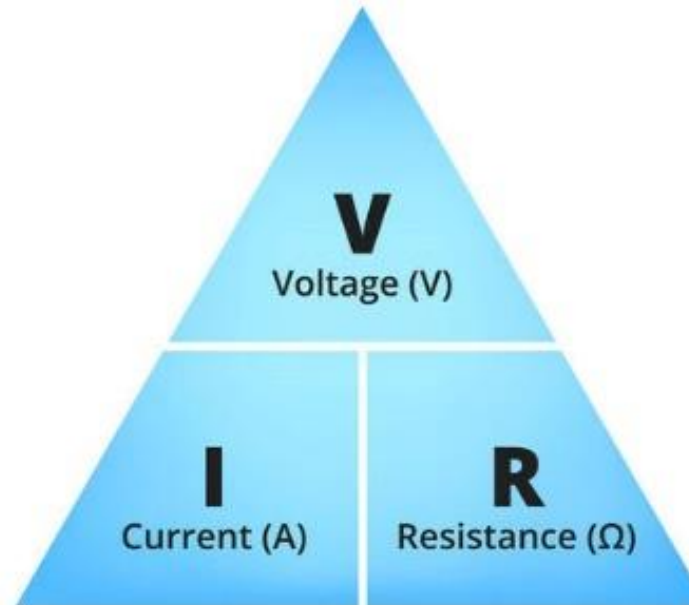

$$V = I \cdot R \leftarrow$$

$$R = V : I$$

$$I = V : R$$

# Electrical Fundamentals & Laws (52-53)

**Watt's Law:** another formula that means power is calculated by voltage times current

Formula is  **$P = V \times I$** .

**P = Power**

**V = Voltage**

**I = Current**

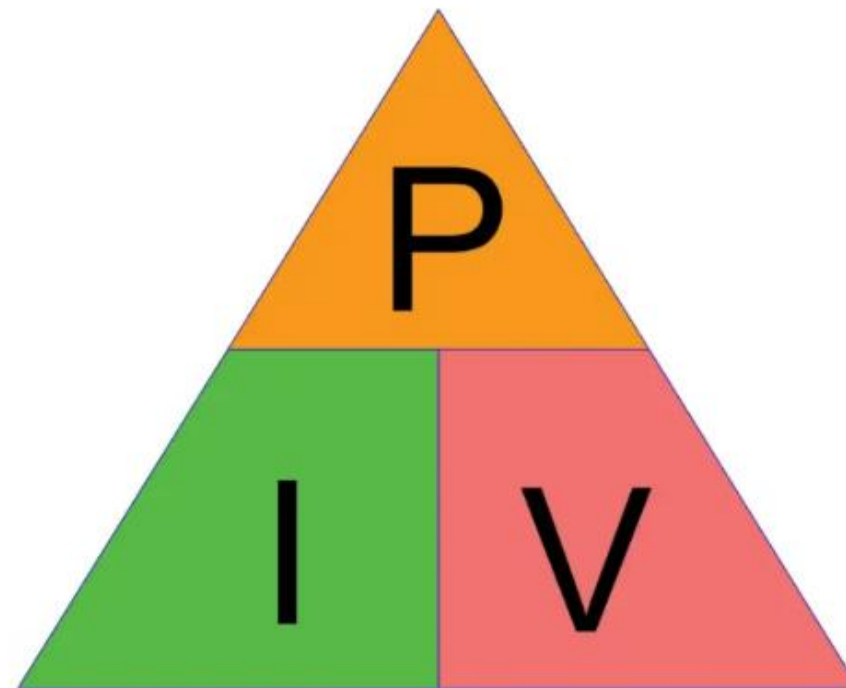

# Electrical Schematic Basics (53)

Drawings or visual representations of electrical connection points between components or systems.

Outlines functionality for an electrical circuit, and serves as basis for beginning of troubleshooting electrical components and systems.

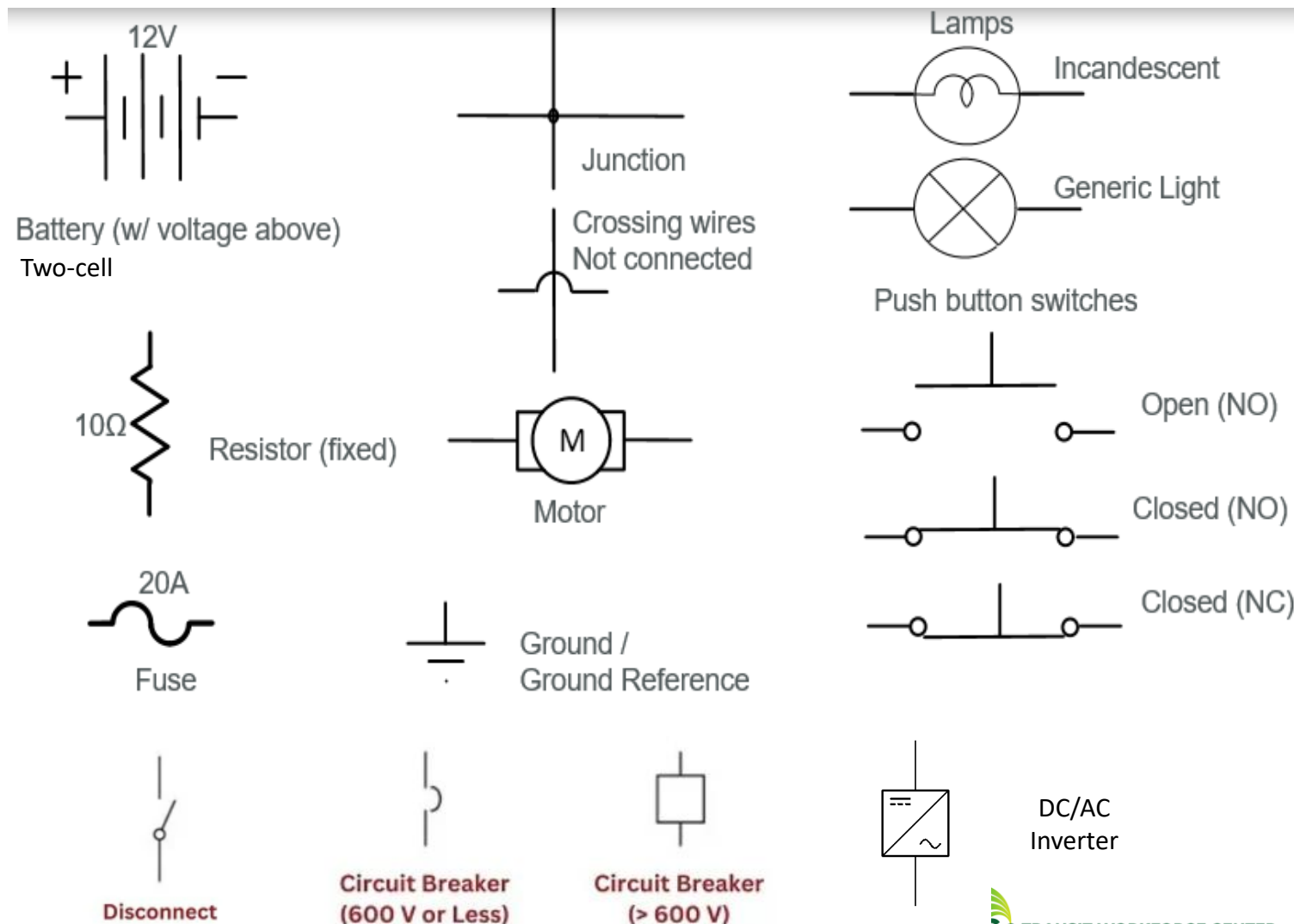

# Electrical Basics V4-hb



Credit: Immersed Technologies, Inc.

# Learning Application 2A

Review the following image and answer the questions.

What variables are used to calculate voltage (Ohm's Law)?

Voltage (V), Current (I) and Resistance (R)

Given a current of 2 amps (A) and a Resistance ( $\Omega$ ) of 5, what is the calculated voltage?

$$V = 10 \text{ v}$$

## OHM'S LAW

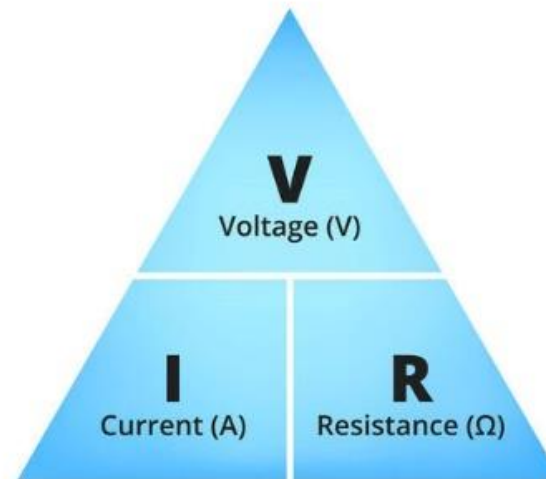

$$V = I \cdot R$$

$$R = V : I$$

$$I = V : R$$

Given a voltage (V) of 18 volts and a current (A) of 6 amps, what is the calculated resistance ( $\Omega$ ) ?

$$\Omega = 3 \text{ amps}$$

## Definition of High Voltage (54)

- **High voltage** as it relates to a battery electric bus is any voltage over **50 Volts**
- Common BEB energy storage systems can total between 100-800 kWh (kilowatt-hours)
  - kWh rating is a measure of energy, equivalent to one hour of electricity at a rate of 1 kilowatt-hour
- All high-voltage components or areas that house high voltage components will be identified via a hazardous voltage label
  - Usually consists of a yellow triangle, a black thunderbolt and some form of warning text.



# Definition of High Voltage (55)

- Some may be marked in red; others marked in yellow (cautionary)
- Always pay attention to labeling
  - **Will be clearly identified and marked**
  - OEM labels may vary
  - Familiarize yourself with OEM manuals (specifically the BEB high voltage systems)
- **Becoming familiar with areas of HV is important**
  - Due to inherent possibility that a sticker could be damaged or removed



# Effects of High Voltage on the Human Body (55)

1. **5 milliamps**- feeling a little bit of a shock. Not necessarily painful and you can let go, but gets your attention
2. **6 to 30 milliamps** –feeling a little pain and muscle shock.
3. **50 to 150 milliamps** - can experience respiratory arrest, severe muscle contractions; possibility of death.
4. **1000 to 4300 milliamps** (1 amp to 4.3 amps), feel ventricle fibrillation (heart pumping out of rhythm), muscles will definitely contract; death is likely.
5. **10 amps or more** have severe burn(s); death is probable.

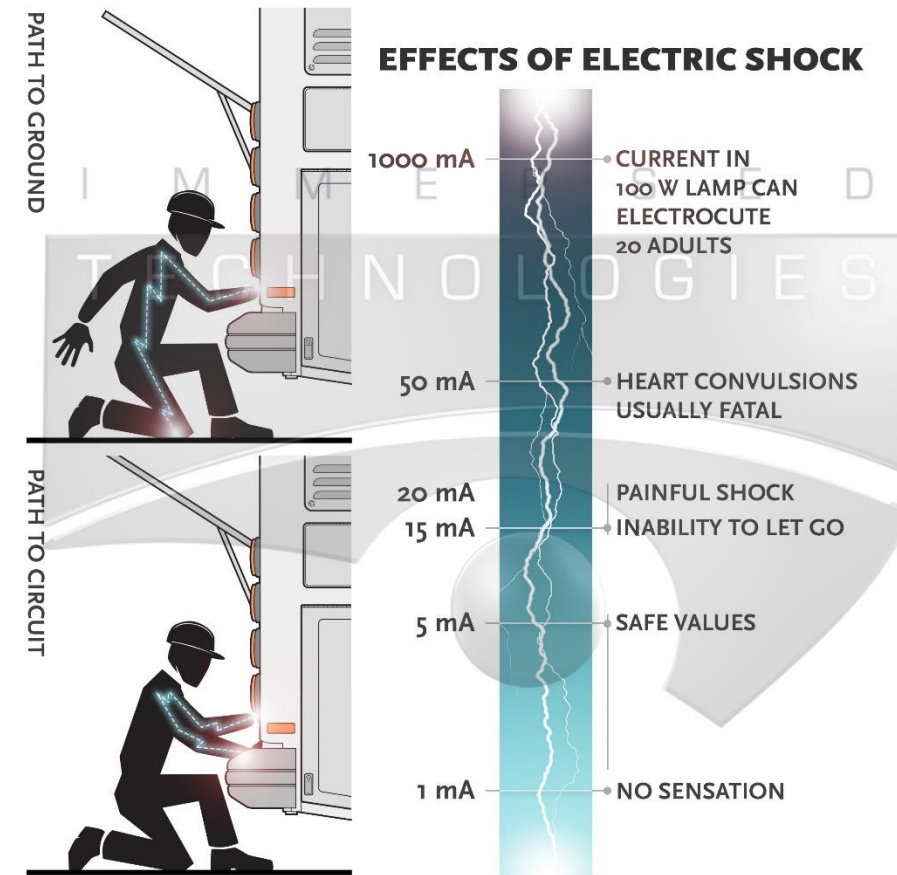

Source: NIH, OSHA, CDC

NOTE: Values given for adult male; values for adult female are slightly lower.



# Safety Considerations, Hazards, and Risks (55-56)

**Hazard** - something that can cause harm

- Hazard Identification means spotting and identifying hazards; electrical, chemical, etc.

**Risk** - the chance, high or low, that any hazard will actually cause somebody harm. Can also be described as exposure to danger, harm or loss

- Identify hazards associated with tasks to be performed and assess risks associated with these tasks which lead to safe work practices and PPE requirements/use (gloves, glasses, fall protection, etc.)

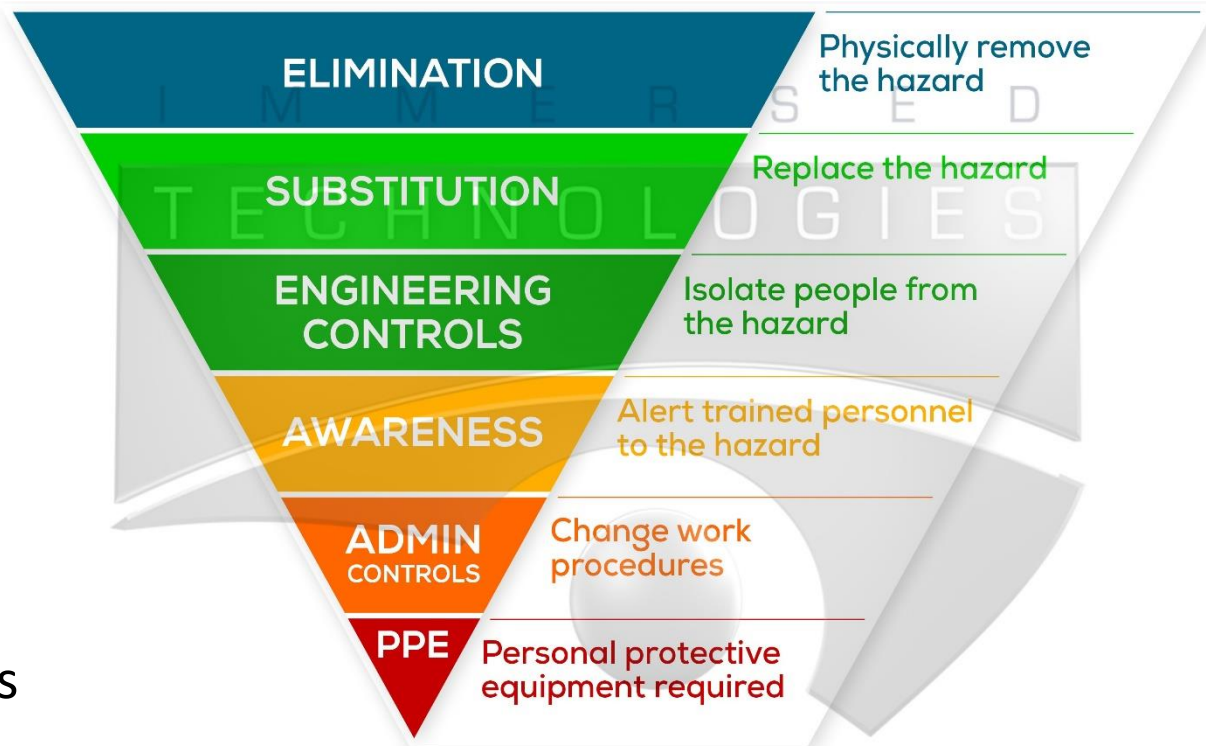

Source: NIOSH



## Safety Considerations, Hazards, and Risks (56)

- **Know the system you are working on**
  - MUST be trained and qualified to work on HV systems. If you are uncertain if this applies to you, ASK.
- **NEVER** assume the system is safely de-energized. “Test before you touch.”
- **DO NOT** pierce, pry open, dismantle or force open any area labeled with the “high voltage” warnings
- **DO NOT** insert any tools or body parts into any holes, cracks, crevices or other openings in or near any areas labeled with “high voltage”



## Safety Considerations, Hazards, and Risks (57)

**NEVER** work on an HV system by yourself.

- **ALWAYS** have a qualified second person as an observer and a safety backup.
- In most cases both members should wear the same set of PPE

Always apply your own lock when performing work on a vehicle.

Think before beginning any work

- What PPE will you need, what are the risks, etc.
- Familiarize yourself with OSHA and NIOSH standards.
- Risks to consider – flash, explosion, gas, shock wave, personal injury, heat, molten material, etc.



# High Voltage Safety Hazards and Risks (57)

## 1. Increased risk of electrical shock hazards and shocks – HV, HV Cabling & HV systems & components

- Be sure to wear PPE.
- Isolate potential energy by performing Lock out/ Tag Out procedures
- Chance to experience injury, burns, even fall

## 2. Arc Flash - A sudden release of energy or undesired electric discharge that generates intense light and heat, radiating at supersonic speeds.

- **Burns:** When an electric arc occurs, it generates immediate extreme temperature and increases risk of severe burns.
- **Metal projections:** Metal can explode when an electric arc occurs and super-heated shrapnel can be projected in every direction



## High Voltage Safety Hazards and Risks (58)

- **Concussive blasts:** a blow to the body caused by the resulting force from an arc flash
- **Falls:** Human instinct is to *recoil* from an arc flash, which could cause a fall from a height of greater than ten feet [ $>10'$ ].
  - Fall-protection is required when working from height: harnesses, work platforms, ladders, etc.
- Risk Assessments and “Predict-Prevent-Protect-Publish” (4 P’s) are crucial for safe maintenance operations.
- Generally, the higher the voltage, the higher the risk.
- Arc Flashes should be a **rare** occurrence when safely working in and around properly maintained electrical equipment

# Knowledge Check [MC]

Choose the correct answer(s). Based on the image below, which of the following is the common formula for calculating voltage (V)?

A)  $I \times R$

B)  $V/R$

C)  $P/I$

D)  $P/V$

## OHM'S LAW

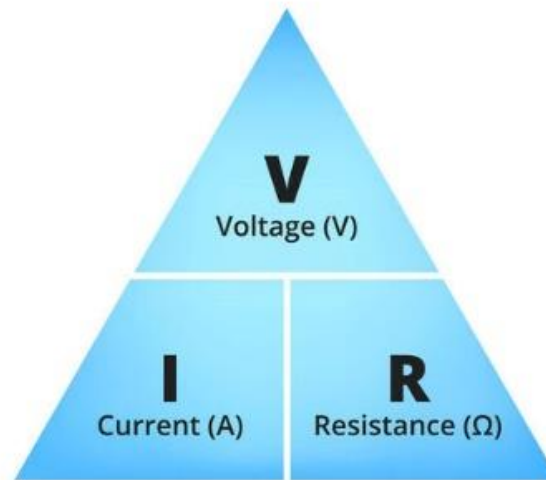

$$V = I \cdot R$$

$$R = V : I$$

$$I = V : R$$

# High Voltage Safety Hazards and Risks (58)

## 3. Thermal Runaway Event

Condition that begins when heat generated within a battery exceeds the amount of heat that is dissipated to its surroundings.

- Once started, the condition will continue, creating a domino effect

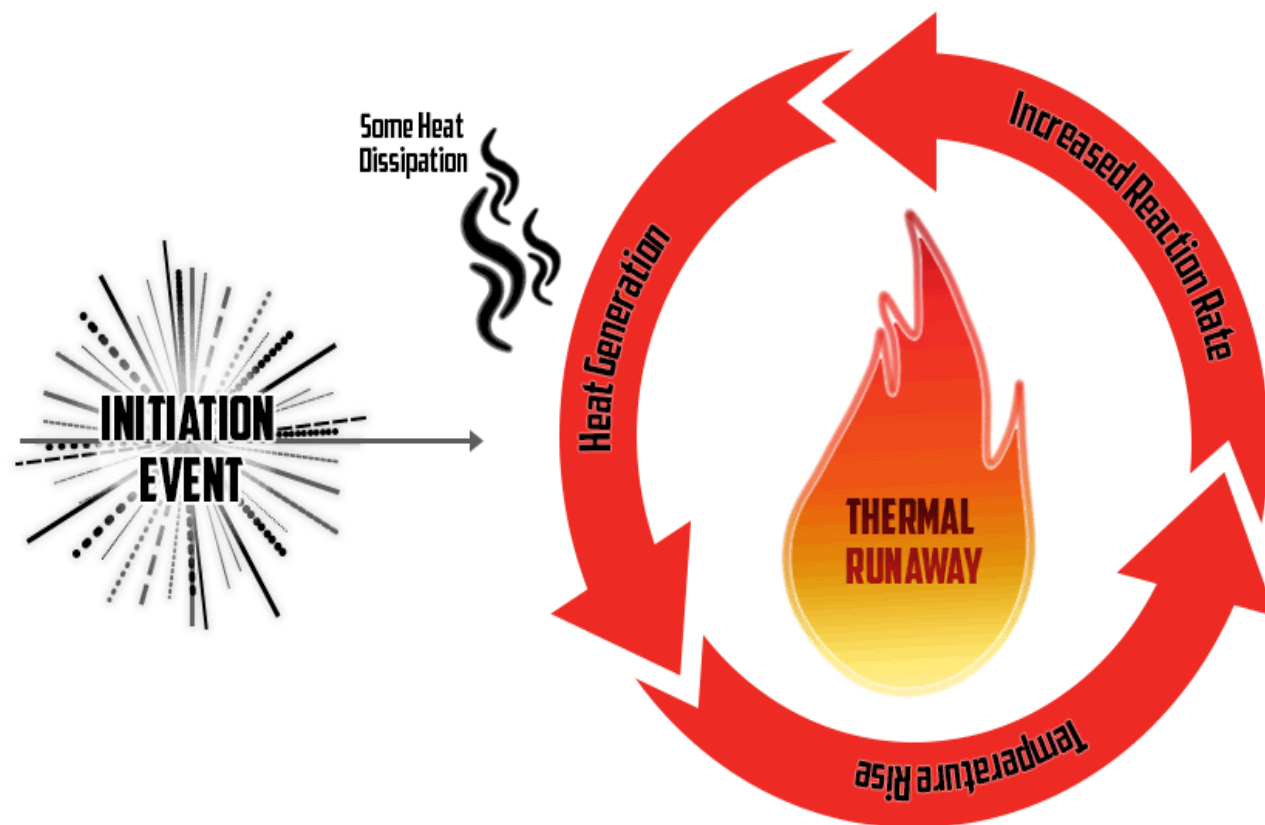



# High Voltage Safety Hazards and Risks (59)

## What to do in the event of thermal runaway:

- If an event does start, best measures are to get away and let safety personnel handle
  - Monitoring, temperature control and venting are critical.
- Important to note: Water **CAN** be used on a lithium ion battery when trying to cool
- Follow PPE and safety instructions from manuals and on vehicle/components





# High Voltage Safety Hazards and Risks (59)

## Thermal runaway prevention:

- Engineering controls and safety features:
  - Flame retardants
  - Ventilation
  - Device monitoring
- Preventive Maintenance
- Familiarization with run controls and shutdown procedures
- Observation of cautions and warnings on the bus and in maintenance manuals
- Familiarization with safety data sheets [SDS]



## HV & Arc Flash Safety (60)

- Any stored energy (even after de-energization) should be treated as if it were a hazard
- In order for electric current to flow, there is a need for a potential difference.
  - When this potential difference is isolated, it's possible (with proper PPE and safety tools) to perform maintenance around energized or live systems.
- **ALWAYS** wear PPE. Better safe than sorry.
  - **Make sure that your gear is rated for the anticipated use or maintenance you expect to perform**
- Regularly inspect systems, subsystems, HV equipment and PPE for wear, damage, punctures, tears or deterioration



## HV & Arc Flash Safety (60)

4 P's Model - An effective model to arc flash management which features:

- **Predict** – this means to calculate and validate, pertaining to any potential hazards or risks to determine the potential severity of the arc flash and its effects.
- **Prevent** – Helps to mitigate the chances of arc flash using principles of prevention. This can be similar to the hierarchy of controls when planning, designing and eliminating risks.
- **Protect** – The ability to reduce risks and hazards with protection and/or the proper PPE, especially if risks cannot be eliminated or removed
- **Publish** – Refers to the collection of information and materials for risk assessment for use in training and providing safety warnings and procedures where risks cannot be eliminated or removed



## HV & Arc Flash Safety (60)

- Know the system you are working on. You **MUST** be trained and qualified to work on HV systems. If you are uncertain this applies to you or if you have any questions... **ASK**
- Performing any work is always safer with HV shut off. Never assume a system is safely de-energized. **Always verify that the HV is off:** “Test before you touch”
- Never work on HV systems by yourself. You need a qualified second person as a safety and an observer.
- Always apply your own lock when performing work on the vehicle, as your safety is ultimately in your own hands.



# HV & Arc Flash Safety (61)

## Any of the following can result in an arc flash:

- Dust
- Dropped tools
- Condensation and moisture
- Corrosion
- Faulty installation
- Accidental touch of conductors
- Equipment failure

## Severity of an arc flash can depend on three primary factors:

- Proximity of the individual to the event
- Size of the resulting explosion
- Time the individual was exposed to the blast

## Compliance of an agency with OSHA and NFPA regulations, primarily the NFPA 70E standard.

- Addresses electrical safety and contains the necessary requirements to mitigate potential shock and arc flash hazards.

# Limits of Approach (61)

1. **Arc Flash Protection Boundary** – or outer boundary, is the farthest boundary from any energized equipment or area. If arc flash occurs, would get first degree burns. Should not be crossed unless you have appropriate PPE on.
2. **Limited Approach** – the distance where any barriers should be set up to offer protection and safe distance for employees.
3. **Restricted Approach** – boundary distance of an increased shock hazard & risk(s). Only qualified personnel should be allowed within limit with required PPE on.

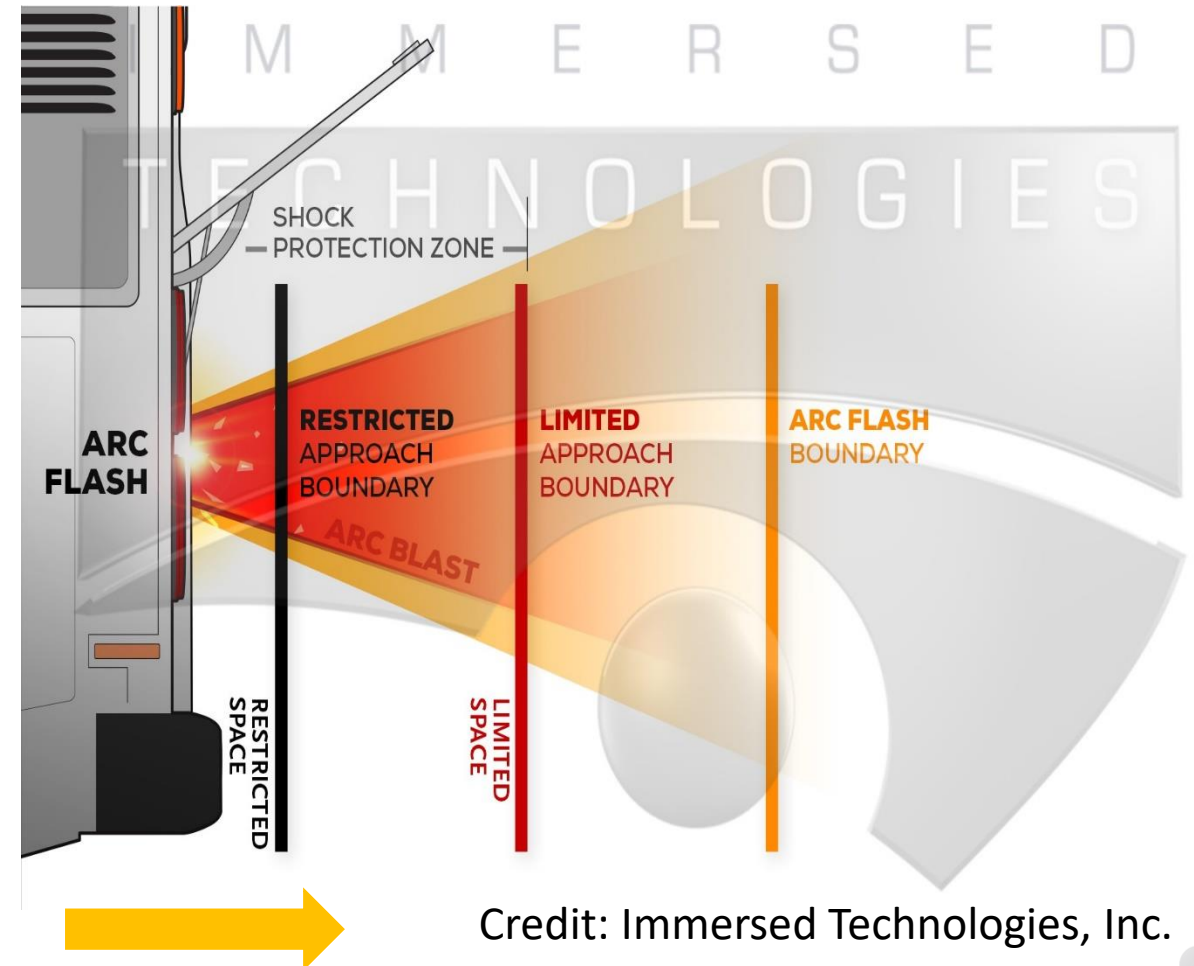

Credit: Immersed Technologies, Inc.

		<b>RESTRICTED</b>	<b>LIMITED</b>	<b>ARC FLASH</b>
<b>AC</b>	<b>151 V – 750 V</b>	<b>12"</b> (0.3 METERS)	<b>3' 6"</b> (1 METER)	EQUIPMENT DEPENDENT
	<b>50 – 150 V</b>	<b>AVOID CONTACT</b>	<b>3' 6"</b> (1 METER)	
	<b>&lt;50 V</b>	<b>NOT SPECIFIED</b>		
<b>DC</b>	<b>301 V – 1 kV</b>	<b>12"</b> (0.3 METERS)	<b>3' 6"</b> (1 METER)	EQUIPMENT DEPENDENT
	<b>50 – 300 V</b>	<b>AVOID CONTACT</b>	<b>3' 6"</b> (1 METER)	
	<b>&lt;50 V</b>	<b>NOT SPECIFIED</b>		

Source: NFPA 70E Tables 130.4(E)(a) and 130.4(E)(b)

# HV & Arc Flash Safety (63)

## Arc Flash Warning Labels



### Arc Flash and Shock Hazard Present

#### ARC FLASH PROTECTION

Working Distance	18 in
Incident Energy in cal/cm <sup>2</sup>	0.4
Arc Flash Boundary	0.9 ft

#### SHOCK PROTECTION

Shock Hazard when covers removed	600 VAC
Limited approach	3.5 ft
Restricted approach	1.0 ft
Glove Class	0

Refer to CSA Z462 for PPE requirements

Equipment: EXAMPLE PANEL

13-21-2022

Std. IEE 1584

SafetyCulture

### Breakdown of a sample warning label:

- Danger or warning header
- Incident energy – amount of thermal energy
- Arc Flash boundary – distance from a hazard someone can stand at and receive 2<sup>nd</sup> degree burns if not protected



# HV & Arc Flash Safety (64)

## Arc Flash Warning Labels



### Arc Flash and Shock Hazard Present

#### ARC FLASH PROTECTION

Working Distance	<b>18 in</b>
Incident Energy in cal/cm <sup>2</sup>	<b>0.4</b>
Arc Flash Boundary	<b>0.9 ft</b>

Refer to CSA Z462 for PPE requirements

#### SHOCK PROTECTION

Shock Hazard when covers removed	<b>600 VAC</b>
Limited approach	<b>3.5 ft</b>
Restricted approach	<b>1.0 ft</b>
Glove Class	<b>0</b>

Equipment: EXAMPLE PANEL

13-21-2022

Std. IEE 1584

SafetyCulture

- Shock Hazard when Cover is Removed – the equipment's voltage level
- Limited approach boundary
- Restricted approach boundary
- Glove class – Proper rating of required rubber insulated gloves
- Arc Flash PPE category rating



## Additional Safety Hazards and Concerns (65)

- **Keep in mind that batteries always have “energy present”**; significant potential energy and present everywhere in the HV systems of a BEB.
- **Heavy component handling (lifting) with battery packs**
  - Battery packs may be located on rooftops so there is the potential for injuries due to falls, thus fall protection is required
- **Silent operation and concerns for service and in the garage so check everywhere**
- **Must be aware of both as an operator and in the operation and vicinity of BEB’s**. Many buses are now equipped with automated announcements and alarms (mainly in-service).
  - Electrical systems could have an effect on pacemakers/personal medical devices
  - Increased battery packs mean increased potential for electrical, chemical hazards.

# Learning Application 2B

Either with a partner or in a group, discuss the following: “How would you identify key safety considerations and risks for each of the following hazards?”

1. Electric shock

2. Arc Flash

3. Thermal runaway event

# Knowledge Check [MC]

Choose the correct answer(s). Which of the following is *not* a distinct boundary outlined by NFPA70E in the Limits of Approach?

A) Arc Flash Protection Boundary

B) Limited Approach

C) Restricted Approach

D) All are distinct boundaries outlined by NFPA70E

## Manual Service Disconnect [MSD] (66)

**Manual service disconnect (MSD)** is a safety device that acts as a two-level plug that can be removed from the bus and quickly isolates the HV battery pack from the HV circuit.

Acts as a shunt or fuse on the positive side of the HV power. Removing it causes an open circuit, preventing current flow. Before removing, ensure that the low voltage (or house batteries) is (are) off or disconnected.

Designs vary by manufacturer, and removal of each requires specific procedures that can be found in the OEMs maintenance and repair manual.

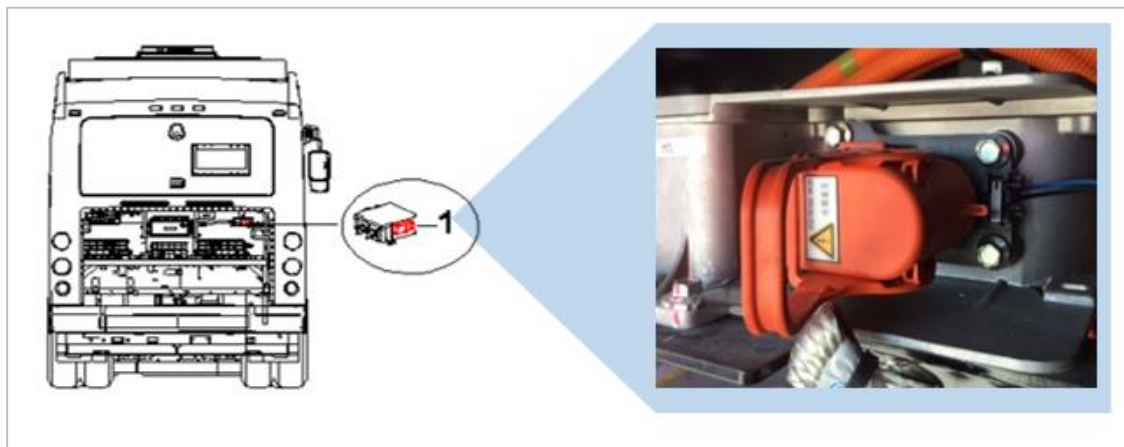

# Manual Service Disconnect [MSD] (67)

***Although it is extremely and highly unlikely to come into contact with any high voltage doing a PM, it is recommended to remove the MSD to prevent any possible current flow.***

**First disconnect this plug without switching off the Battery Disconnect Switch, EXCEPT for emergencies.** There is no need for special PPE in relation to HV during a routine PM inspection.

OEM recommendations will vary

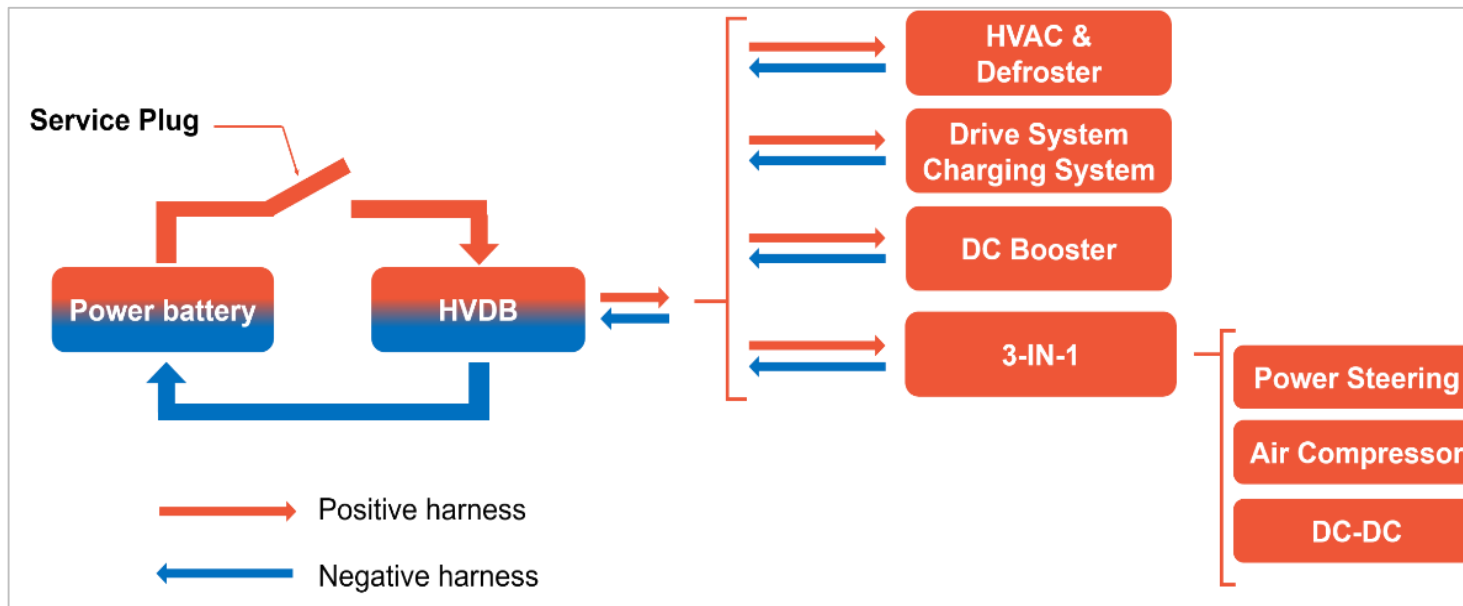

# High Voltage Interlock Loop [HVIL] (67)

The **High Voltage Interlock Loop (HVIL)** is a single low voltage circuit which passes in series through high voltage connection points on the vehicle.

Helps prevent unintended high voltage exposure to technicians. A circuit installed to detect whether high voltage enclosures are opened, when connectors are removed and/or components are damaged.

Starts and ends inside at least one low voltage controller. The responsible controller outputs a low voltage signal onto HVIL circuit and looks for the signal to be returned to the controller after going through the loop.

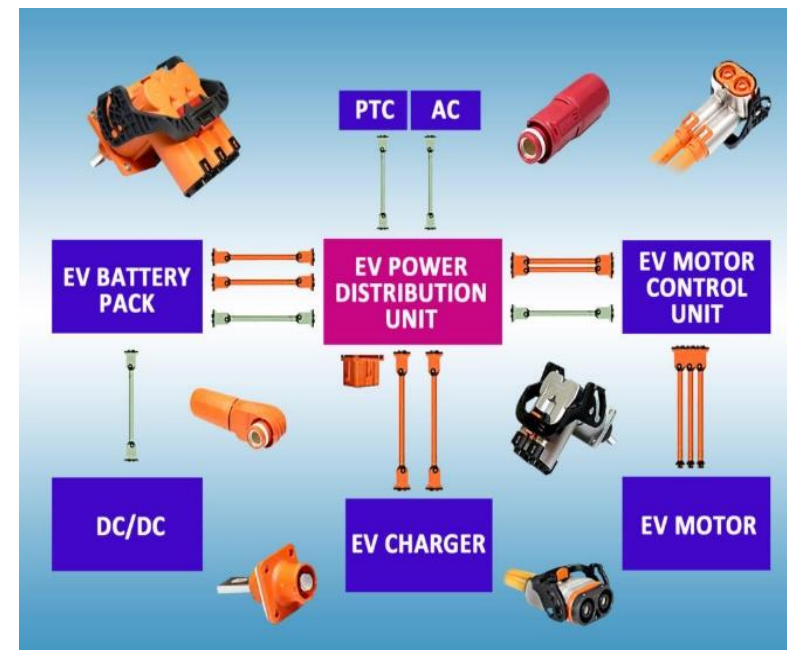

# High Voltage Interlock Loop [HVIL] (68)

- **This circuit runs through the HV junction box and every HV device to monitor connections any break will disable the HV system.**
  - Troubleshooting this system will require that the vehicle be in a “low voltage on” mode of operation.
- Ensure that the vehicle has all LOTO procedures verified before you start troubleshooting any HV systems
- **Designed to prevent unexpected exposure to HV, not intended as a way to isolate the High Voltage system.**
- HV isolation should always be accomplished via the LOTO process.

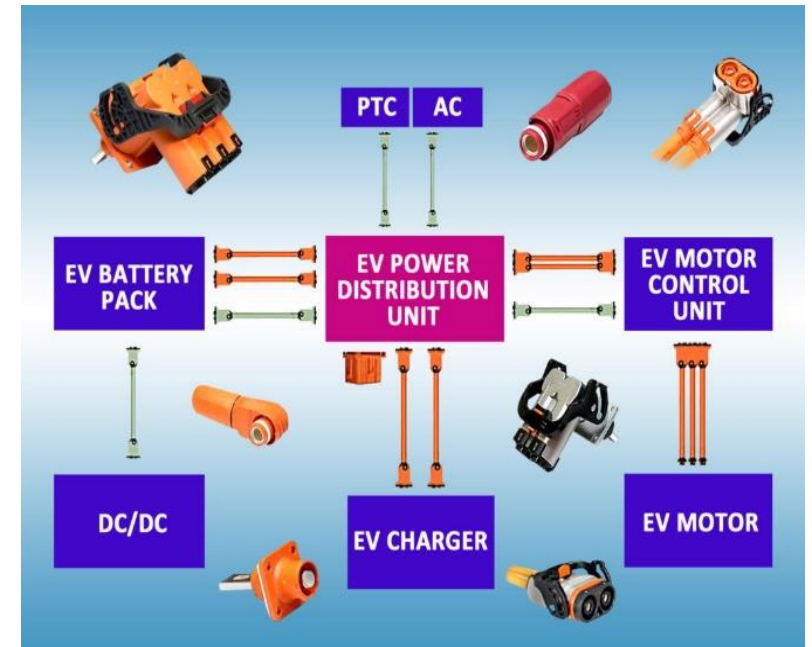



# High Voltage Interlock Loop [HVIL] (69)

- If HV connection to HV component is removed the HVIL loop will be broken
  - As a safety feature, HVIL loop serves to ensure HV contactors in ESS batteries are opened (and HV is contained) if someone tries to access HV while energized
- HVIL loop is always active when bus low voltage system is on.
- Removing power to LV system automatically ensures contactors in ESS are open

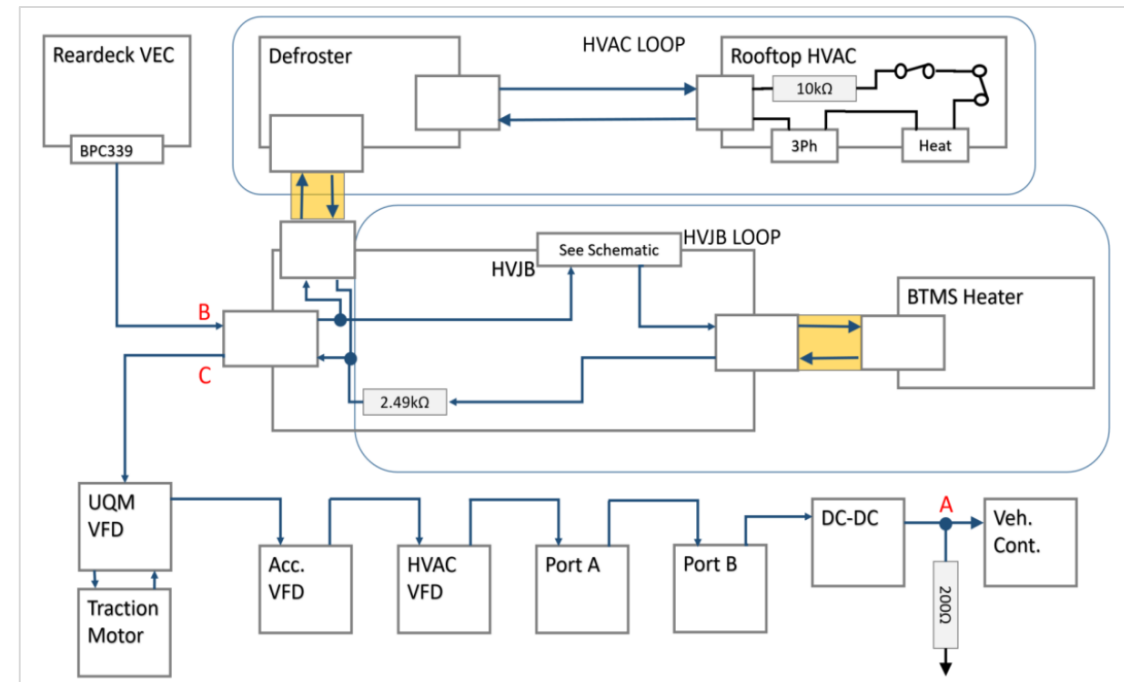

All OEMs will handle HVIL slightly different



## Additional Notes on HVIL Safety (69)

- Each and every access panel and connectors in a high-voltage system will have either a physical switch or wire-loop interconnected on a single low-voltage (12/24v) loop.
- HVIL loops work off either 12V or 24VDC and will see any system voltage below 10.8 or 22.6 V as an open and will shut down the HV.
- BEBs have many HVIL switch and connectors.
  - Be sure to check all open covers and that everything is closed. Otherwise the bus will shut down and be immobile.
- **ALWAYS fix any HVIL issues and never bypass the switches, even for diagnostic purposes in the shop.**

# Additional Notes on HVIL Safety (70)



## Passive Propagation Resistance

- Safety feature within battery modules/ESS
- Allows individual cells in a battery to be encased in a special foam material
- Acts as a strong isolator between cells

# Knowledge Check [MC]

Choose the correct answer(s). What is a thermal runaway event?

A) A sudden release of energy or undesired electric discharge generating intense light and heat, radiating at supersonic speeds

B) The electrical disconnect verification procedure(s) for a BEB

C) The chance (high or low) that any hazard will actually cause someone harm

D) A condition that typically occurs due to increased heat and temperature conditions within the battery packs, that is created when the heat generated within a battery exceeds the amount of heat that is dissipated to its surroundings.

# Shop Safety Practices (70)

## Lock out/Tag Out or LOTO

- A series of steps to de-energizing the bus which makes the bus safe for work.
- When followed correctly, signals to others that work is being performed in high-risk areas, and the vehicle **should not** be re-energized.
- Done with a lock and tag system that provides a record of a technician's contact information and duties in that area.

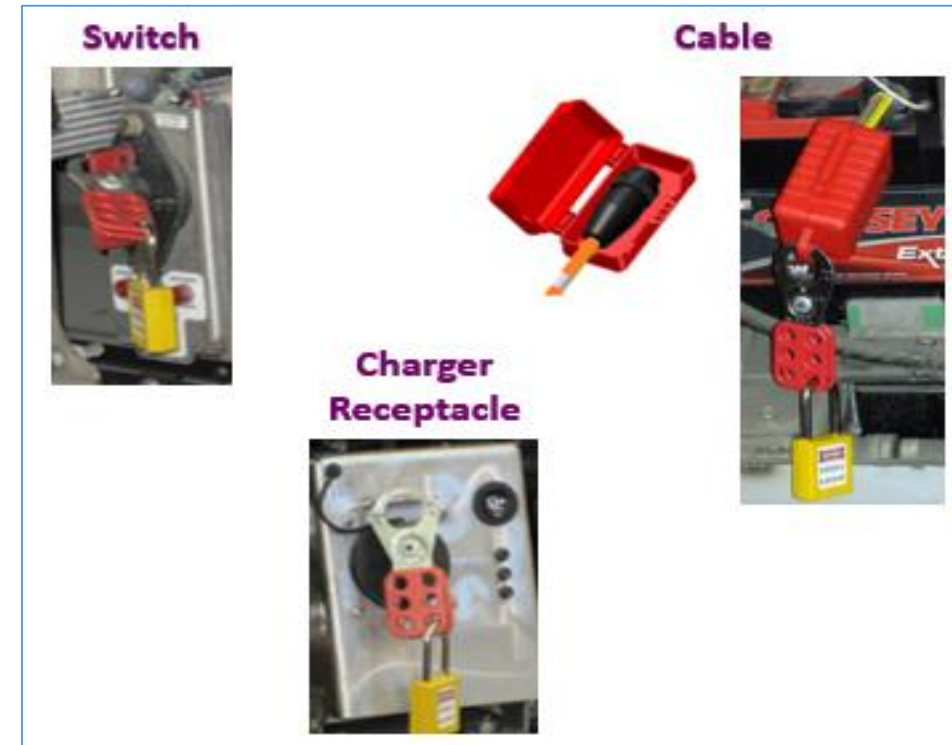

***\*Only qualified personnel should be performing LOTO at their agency.***

## Shop Safety Practices (70)

- LOTO is a two-person procedure
  - The technician is observed by a second qualified person wearing proper PPE with an electrical rescue hook in hand.
- BEBs have multiple sources of energy. Locking out the vehicle must always be done to the manufacturer's process.
- Always follow the procedure specified by the OEM or vendor.

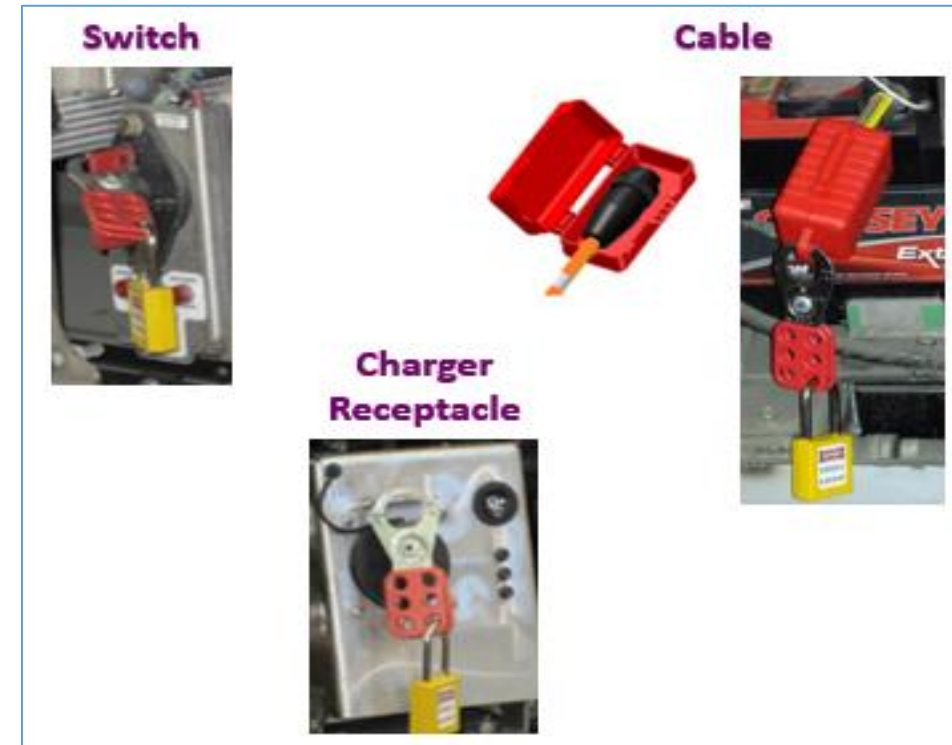

***\*Only qualified personnel should be performing LOTO at their agency.***



## Shop Safety Practices (71)

### Why do we lockout and tag out?

- To isolate every source or potential source of energy, and be 100% sure no one can re-energize a circuit. LOTO is a two-man verification procedure that the system is 100% safe to work on. **Otherwise assume that high voltage is present.**
  - Technician performing the job should be watched by a second qualified person.
  - They should also wear proper PPE and gloves, while having an electrical rescue hook in hand if needed.
- Keep in mind - BEBs will have multiple sources of energy.
- Tagout devices act as a prominent warning for others to not reenergize
- **NEVER** rely on just computers or systems to keep you safe



## First Aid & CPR (71-72)

- Locate and turn off the source of the hazard. If not accessible or feasible to do so, remove source plug or power supply to the area
- If needed, attempt to remove the victim from the hazard(s) with your insulated equipment. Be sure to maintain isolation and approach distance as to avoid closing the circuit.
- If you have the training, you may administer CPR and First aid/an AED device
- Call 911 to notify rescue personnel and to arrive on the scene as soon as possible

**It is recommended that you seek out first aid training specializing in electrical hazards**





## Releasing Victim from HV (72)

**You and the observer should be in the same PPE and have safety/rescue equipment on-hand.**

Attempt to remove victim from electrical source

- Use a shepherd's hook or similar device
- Isolate the electrical source if possible

**DO NOT attempt to move/pull person from source without protection**

Once removed, notify emergency personnel immediately.

- It may be necessary to perform CPR until emergency medical staff arrive.
  - However, **DO NOT** attempt first aid or CPR if you are not trained to do so. If you have not been trained, 911 personnel can instruct you over the phone.



## Releasing Victim from HV (72)

Not recommended to move or pull a person away from the electrical source without protection as you may become energized as well.

May be necessary for you to perform a “*last stance*” effort if you cannot perform a non-conductive release.

- This is attempting to remove someone from an electrical source using your own body.
- Highly dangerous and can lead to being shocked or incapacitated yourself
- **This is not endorsed as a method for rescuing someone from HV unless absolutely necessary.**

# Learning Application 2C

Either with a partner or by yourself, discuss and determine primary functions of BEB safety features introduced in this section. You may write in this section or on a separate page.

**1. Manual Service Disconnect [MSD]**

**2. High Voltage Interlock Loop [HVIL]**

**3. Passive Propagation Resistance**

# Knowledge Check [True/False]

It is critical that the safety observer (monitor/checker) wear the same PPE while in the same boundary zone as the person testing for the absence of voltage.

TRUE

FALSE



## Shutting Down HV Quickly (73)

- Identifying any HV locations and components- such as the traction motor- is critical to working safely and managing risk.
- ***“Knifing “the bus (low-voltage battery disconnect switch)***
  - Design of these loops will vary between OEMs, but the premise is always the same:  
A low-voltage loop which is always monitored by every electronic controller unit.  
Open any portion of the loop and the high-voltage contactors are all opened.
- ***In some cases it may be necessary to remove the manual service disconnect (MSD).***
  - Locations of the MSD will vary by manufacturer, but at a minimum can always be found at, or near, a battery pack
  - May be necessary to remove MSD to shut down HV
  - Location, design and removal process vary by OEM

## Emergency Response (74)

A **first responder** is typically emergency medical crew, fire department and police department personnel.

However, the **vehicle operator** often plays the largest initial role in responding to in-service accidents & incidents.

- Responsible for knowing how the vehicle operates, understanding lights and alarms.
- May be responsible for communicating to road supervisors, maintenance, and emergency personnel



## Emergency Response (74)

Agencies need to be proactive in working with **Emergency Responders** to identify the specific risks and hazards associated with BEBs, and describe the response procedures in case of catastrophe.

Properties must prioritize first responder training to maintain awareness of protocols to ensure public, passenger, and personal safety.



## Emergency Response (74)

**Maintenance crew** typically have responsibility to make any repairs that need to be done, but may also be responsible for towing the bus.

- In most instances, will be considered 2<sup>nd</sup> responders
- Consulted for mechanical/technical expertise in handling vehicles post-incident.

**Tow truck drivers** also considered 2<sup>nd</sup> responders

- Need to know isolation distance and time following an undesired discharge of energy (window of the vehicle's re-ignition potential)
- Typically between a 24 and 72-hour isolation period





## Emergency Response (75)

*Road supervisor* - If the operator is out in service and come across an electrical issue with their vehicle, what protocols are in place and contact dispatch.

Instrumental in assessing, reporting and following-up on the accident/incident.

- a. Dispatch immediately assesses the situation, take the information down and contact the road supervisors, who then respond to the scene.
- b. Most are the central person for taking action and working with maintenance crew and first responders if things escalate.





## Emergency Response (75)

**Every agency will have a process in place for safely getting the vehicle over and secured.** These include (but not limited to):

- As soon as possible safely pull over/off the road
- Secure the vehicle (Park-Parking Brake On-Four Ways On-Vehicle Off if necessary)
- Assess the situation and contact dispatch and relay issue/concern
- If a safety issue (fire, smoke, etc.) – get passengers off of the vehicle and a safe distance from the vehicle



## Emergency Response (75)

These buses are designed with many safety features to warn of issues and to prevent issues, coupled with engineering features and emergency service protocols

- Attention, procedures/protocols, actions and communications should allow all situations to be managed.
- Follow-up; review and learning from all incidents/accidents go a long way in ensuring risks and hazards are minimal and safe operations.

**Prior to any of this the training departments of the company/property will have put together Hazardous Communications and Protocols to deal with any potential issues related to these buses and will have worked closely with local municipalities to go over these response protocols and requirements.**



END OF DAY 1

# Section 2-3: Personal Protective Equipment [PPE]



# PPE DEMONSTRATION – PPE use and inspections

# Personal Protective Equipment [PPE] (76)

The category ratings below identify the NFPA70E primary category ratings:

PPE Category 0: For Shock hazard only

PPE Category 1: Minimum Arc Rating = 4 calories/cm<sup>2</sup>

PPE Category 2: Minimum Arc Rating = 8 calories/cm<sup>2</sup>

PPE Category 3: Minimum Arc Rating = 25 calories/cm<sup>2</sup>

PPE Category 4: Minimum Arc Rating = 40 calories/cm<sup>2</sup>

**Most BEB tasks and maintenance will not require use of any PPE above Category 2 rating.**



# Personal Protective Equipment [PPE] (76)

Category 0 - Shock Hazard PPE includes:

- HV rubber gloves and leather overlays
- Electrical Hazard [EH] rated safety shoes
- Safety glasses

Rankings are provided requirement to obtain the appropriate PPE at the amount of energy on material or layers that lead to a 50% reduction of 2<sup>nd</sup> degree burns.

**Check out the latest NFPA70E for more information.**





# Class 0, High Voltage Gloves (77)

ASTM Labeling Chart Natural Rubber Electrical Insulating Gloves			
Class Color	Proof Test Voltage AC/DC	Max. Use Voltage AC/DC	Insulating Rubber Glove Label
00 Beige	2,500 / 10,000	500 / 750	10
0 Red	5,000 / 20,000	1,000 / 1,500	10
1 White	10,000 / 40,000	7,500 / 11,250	10
2 Yellow	20,000 / 50,000	17,000 / 25,500	10
3 Green	30,000 / 60,000	26,500 / 39,750	10
4 Orange	40,000 / 70,000	36,000 / 54,000	10



Class 0 gloves with a **RED** label required.

Rubber and leather gloves (leathers are worn over top of the rubber gloves ) are foundational safety gear for keeping yourself safe when working near high voltage equipment or in the act of locking out and confirming that lock out.



## Class 0, High Voltage Gloves (78)

- **Do not use nitrile shop gloves if you are working in and around HV. Class 0 Rubber Gloves are required.**
- The color of the rubber can vary, but the color on the label is specified by the ASTM standard. Gloves can be multiple colors (orange, black, etc.), but they will always have the ASTM tag that defines the safe work limits: 1000VAC and 1500VDC in most BEB cases.
- As a best practice, leathers should always be worn over the rubber gloves to protect from nicks, scratches and cuts, as well as providing an additional layer of protection.



## Class 0, High Voltage Gloves (78)

**With gloves, keep in mind: De-energization of a bus could take several hours**

As a best practice, leathers should always be worn over the rubber gloves to protect from nicks, scratches and cuts, as well as providing an additional layer of protection.

As mentioned, these are rubber gloves and will be hot and not always comfortable, so some technicians choose to wear light cotton gloves underneath the rubber gloves. This is not necessary from a safety perspective but can improve the comfort.

*NOTE: Some agencies may have a storage unit and sign out system for glove use*

# Knowledge Check [MC]

Choose the correct answer(s). Which of the following is *not* true of the High Voltage Interlock Loop [HVIL]?

A) When a failure is detected in this circuit **and** the parking brake is set, the vehicle controller will respond with an emergency high voltage shutdown to remove any potential high voltage exposure quickly as possible

B) You can disconnect this without switching off the battery disconnect switch first

C) Troubleshooting this system will require that the vehicle be in a low voltage on mode of operation

D) HVIL is a system designed to prevent unexpected exposure to HV – not intended as a way to isolate the HV system

E) All are considerations of the HVIL safety features

# Electrical Hazard Rated Safety Shoes (78)



- The shoe/boot is insulating from the ground.
- **Not the same as ESD-rated footwear.**
  - Grounded to discharge static electricity.
- Composite and steel toes are acceptable.
- Identified by the lightning-bolt symbol on the tongue.

# HV Glove Inspection & Testing (79)

1) **“Blow-and-fold” technique** - an inspection procedure prior to any use of the gloves. This test happens when someone rolls the gloves in their hands or inflates them manually to better expose imperfections and air leaks. Checks or tests for:

- Holes, perforations, tears, cuts, cracks, burn marks, air bubbles, encrusted or bonded material

2) **Use of a specialized glove inflator**- The usual frequency for periodic inspections is between 30 and 90 days. May not be available in all shops

- Do not inflate beyond 1.5x standard size
- Allows for closer inspection of webbing between fingers and gauntlet



# HV Glove Inspection & Testing (79)

## 3) Dielectric tests (send away to a lab)

- Send to a recognized, qualified lab to maintain glove insulation properties.
- Date of dielectric tests must be logged/printed on each glove. Will be stamped on gloves when first purchased
- New tags/dates will be added to confirm retests
- Rubber gloves should be replaced every 6 months (from date of service) or annually if they have been on the shelf



# Section 2-4: Safety & Testing Equipment



# Safety & Testing Equipment (80)

Any device that can be used to take measurements; some measure only one specific unit:

- **Ammeter** – measures current
- **Voltmeter** – measures only voltage
- **Ohmmeter**- measures resistance; gives an actual resistance unit between two points
- **Megohmmeters**- measures very large resistances
- **Milli-ohmmeter** – measures very small resistances, often used to verify HV equipment repairs



Most common is a **digital multimeter** – combines several measuring devices in one

## Verify Test Verify (81)

A three-step process to confirm that the absence of voltage at an energy source after de-energization. Also known as “**Live, Dead, Live.**”

1. Start by testing a known good voltage source to confirm the multimeter is working.
2. Next with proper PPE and following OEM testing procedures, test the high voltage circuit to confirm there is **no voltage present**.
  - In most cases, testing positive to negative, then chassis to each is required.
3. Finish by testing the same known-good voltage source again to validate that your multimeter readings are correct.





# DEMONSTRATION – Voltage Reading

## Current Probes [1000 Category III/600 Cat IV] (82)



A current probe is a meter that has clamps on the end which open and close, allowing for the “jaws” to clamp around an electrical component or conductor.

- Allows for indirect measurement of current without the need for physical contact, or disconnecting and needing insertion through a probe.

Some may also allow for reading phase and waveform measurements, and may be able to be incorporated into a general-purpose multimeter

## Insulated Rescue Hook (82)

- An essential tool for technicians working near HV or on a BEB (may also be called a Shepard's hook)
- Utility tool that acts as an extension pole for you or another person to safely move or remove someone who may have been injured or incapacitated by a source of HV or electrical hazards
- The extended length of the hook allows the person using it to maneuver the incapacitated person without exposing themselves to the same source of electrical hazard.



## Fire Extinguisher (82)



- A canister filled with materials & agents that when triggered by a person will expel said materials onto a source of heat or flames that offer a cooling or freezing effect.
- Other types of multipurpose extinguishers with additional categories and rankings include Class B and Class C fire extinguishers
- ABC fire extinguishers offer fire reduction qualities not only for Class A fires, but also Class B and Class C fires.
  - **ABC extinguishers have little effect on batteries experiencing thermal runaway**

# Phase Rotation Meter (83)

- An instrument (meter) that shows the direction a 3-phase motor would rotate when hooked up to a power source.
- Some meters will be able to indicate the orientation and whether a phase is live or not.
- Typically used for verification of repairs
- By using this instrument to identify a phase, rotation and orientation, helps with making motor adjustments and reducing or preventing damage to any electrical or motor system.



## Safety Barricade (83)

- “A physical obstruction such as tapes, cones, or A-frame type wood or metal structures that provides a warning about, and limits access to, a hazardous area”
- Setting up a safety barricade (particularly around HV areas of a BEB) provides a physical barrier around the area being worked on
  - Standard minimum distance to place a barrier is **at least 4 feet (4')** away from hazard area.
  - Cones are acceptable in place of a barricade
  - Some scenarios may have safety observer be responsible for keeping others outside the 4' zone when specialized equipment is not available

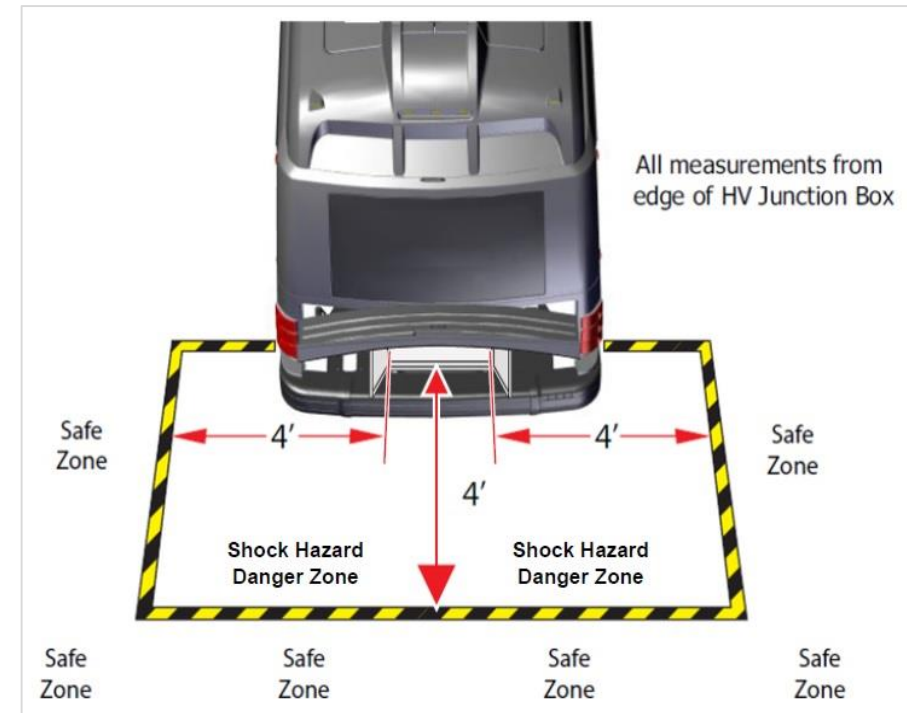



## Insulated Tools (84)



They often are sold in group kits. These can include:

- Sockets
- Pliers
- Open End Wrenches
- Screwdrivers
- Torque Wrenches (3/8,1/4)
- Insulated LED lights

- Insulated hand tools follow ASTM F1505-01 and IEC 900 standards & necessary for compliance with OSHA and NFPA 70E.
- It is important to have these insulated toolsets available in the shop, not every technician needs to own one

# Insulated Tools (84)

## HV insulated mat

- Rubber floor covering or mat offering protection/insulation in an area you may stand in with electrical hazard conditions
- Made of blended dielectric materials (higher internal resistance) and should be tested approximately every 2 years

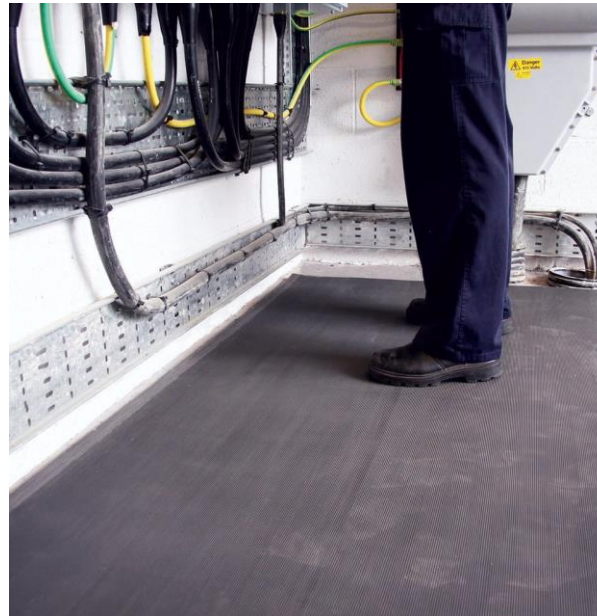

# Section 2-5: De-Energizing [Lock-out/Tagout] of BEB Electrical Systems



# DEMONSTRATION – LOTO Procedures

# Proterra Catalyst Demonstration



# Learning Application 2F

1. Where is the Master Switch located?
2. Where is the Master Disconnect Switch located?
3. What components do you need to apply multi-lockout tagout devices to?
4. How do you determine that your voltmeter works properly?
5. Do you need to verify the 12/24 VDC contactor has no voltage on either side of the contactor? What is the reference point?
6. What is needed to be done in order to access the high voltage junction box [HVJB]?
7. Describe the PPE testing the man performed.
8. What is the voltage to be verified from the inlet busbars coming to the batteries?
9. What is the verified voltage needed from the traction motor inverter connection and any HV components?
10. What is the last part of the process?

# New Flyer Demonstration

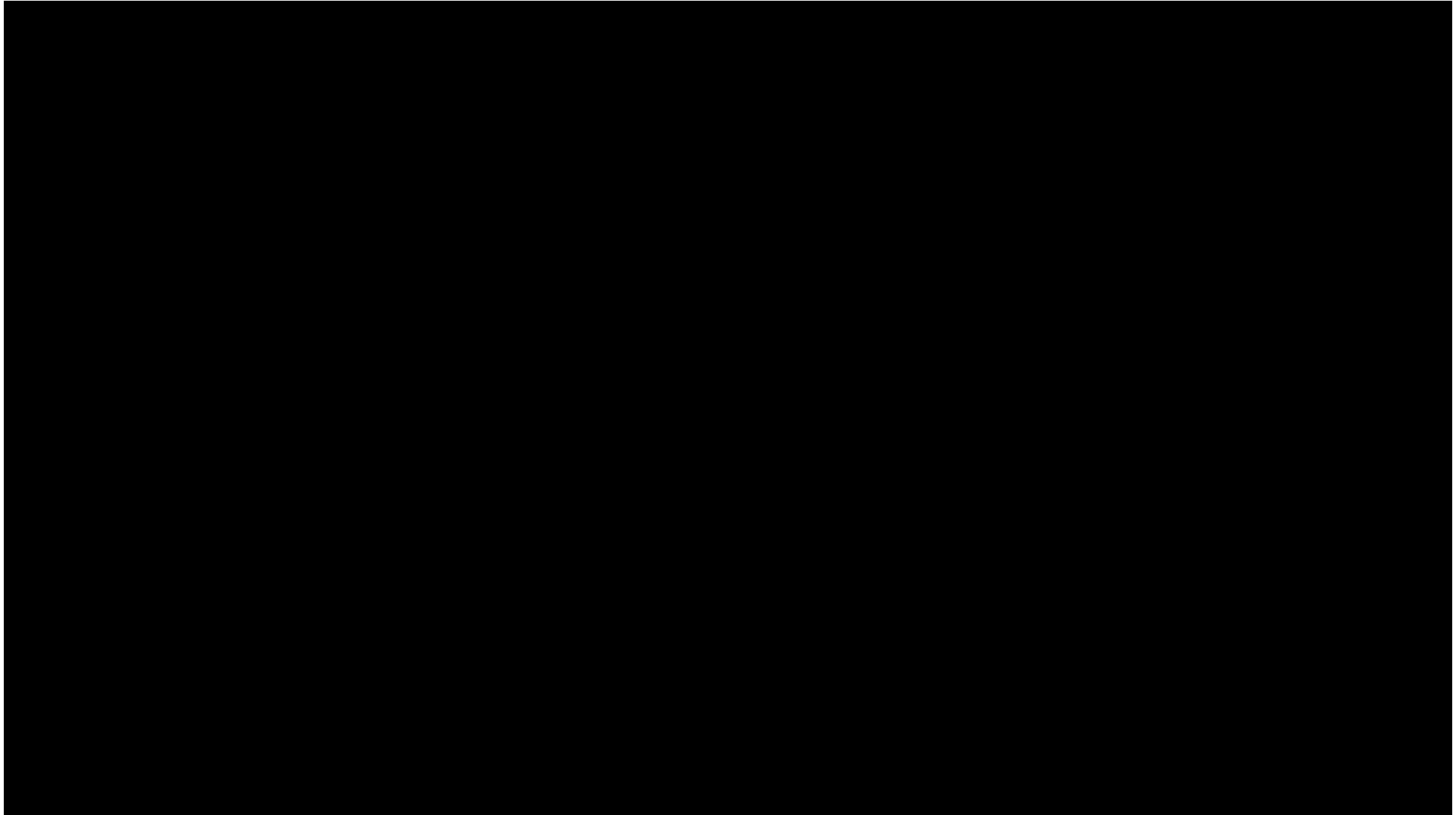

# Learning Application 2G

1. What position should you set the Master Run Switch to?
2. What should you do with the Battery and High Voltage Interlock switches?
3. What needs lockout-tagout devices in the rear curbside panel?
4. Should you ensure there is no voltage on the 12/24VDC battery bus bars?
5. What do you measure between with your voltmeter inside the fuse box?
6. How often should you inspect and/or test the HV and how?
7. Which direction do you measure on the busbars?
8. What do you measure after you check between busbars?
9. How do you determine if current is flowing through the manual service disconnect [MSD]?
10. How many MSDs do you remove?



## Summary (86)

1. Much easier to keep yourself and others safe while performing BEB maintenance once you understand more fundamental electrical concepts.
2. Keep in mind your safety considerations to reduce the likelihood of hazards like arc flash and thermal runaway event
3. Recognize the importance of de-energization/lockout-tagout procedures, built-in safety features and regulation standards for electric vehicles
4. Recognize necessary PPE needed for BEB maintenance and the related safety and testing equipment
5. Demonstrated the process of de-energization for two model BEBs